

TOOL HOLDERS

HSK-T

HSK63T

D

C

L

N

刀柄尺寸
Taper Size

可转位刀片夹紧方式
Insert Clamping Way

可转位刀片形状
Insert Shape

刀杆偏角
Holder Angle

可转位刀片后角
Insert Clearance Angle

HSK63T
HSK100T

| | | |
|---|--|--------------------------------------------|
| C | | 从上面压紧 Clamp |
| D | | 从上面穿过孔压紧 Clamp/inserts with center hole |
| M | | 从上面用孔压紧 Pin/Clamp |
| P | | 杠杆压紧 Pin/Wedge or Lever |
| S | | 通过孔拧紧 Screw |

| | | |
|---|--|-----|
| C | | 80° |
| D | | 55° |
| S | | 90° |
| V | | 35° |
| W | | 80° |

| | | |
|---|--|--------|
| A | | 90° |
| B | | 75° |
| D | | 45° |
| G | | 90° |
| H | | 107.5° |
| J | | 93° |
| L | | 95° |
| M | | 50° |
| N | | 62.5° |
| P | | 117.5° |
| Q | | 107.5° |
| R | | 75° |
| S | | 45° |
| U | | 93° |
| V | | 72.5° |

| | | |
|---|--|----|
| B | | 5° |
| C | | 7° |
| N | | 0° |

HSK

HSK

63T

刀柄款式
Taper

HSK

刀柄尺寸
Taper Size





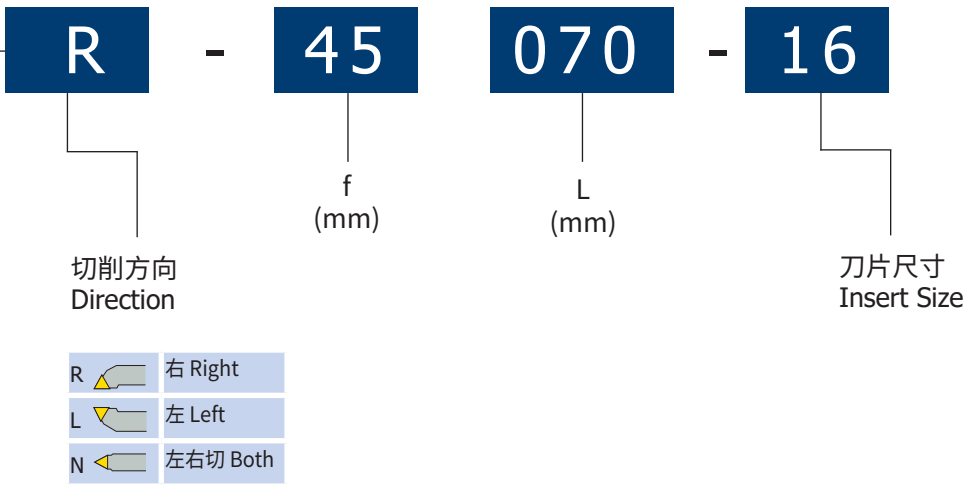



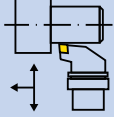
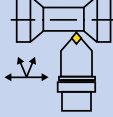
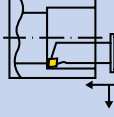

HSK63T

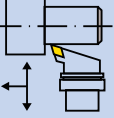
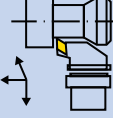
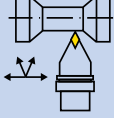
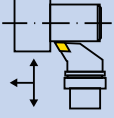
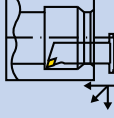
HSK100T

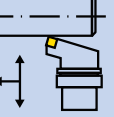
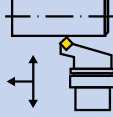

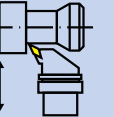
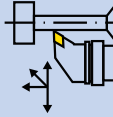
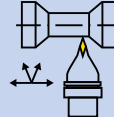
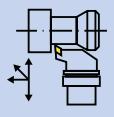

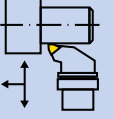

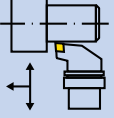
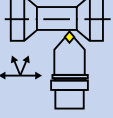
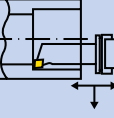
车刀刀体 HSK-T 车刀刀体 HSK-T 产品总览

HSK

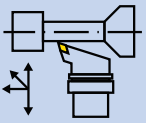
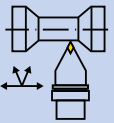
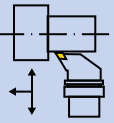
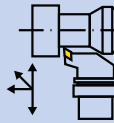
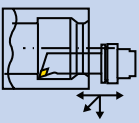
| 刀片形状 Insert Shape | DCLN PCLN 95° / 80° | DCMNN PCMNN 50° / 80° / 50° | DCLN PCLN 长型 95° / 80° | | |
|---------------------------------------------------------------------------------------|-------------------------------------------------------------------------------------|-------------------------------------------------------------------------------------|-------------------------------------------------------------------------------------|---------------------------------------------------------------------------------------|-------------------------------------------------------------------------------------|
| C  |  |  |  | | |
| 刀片形状 Insert Shape | DDHN PDHN 55° / 93° | DDJN PDJN 55° / 93° | DDNN PDNN 62.5° / 55° / 62.5° | DDUN PDUN 93° / 55° | DDQN PDQN 长型 107.5° / 55° |
| D  |  |  |  |  |  |
| 刀片形状 Insert Shape | DSBN PSBN 90° / 75° | DSSN PSSN 45° / 90° | | | |
| S  |  |  | | | |
| 刀片形状 Insert Shape | DVPNR DVPNL 117.5° / 35° | DVUNR DVUNL 93° / 35° | DVWNN 72.5° / 35° / 72.5° | DVJNR DVJNL 72.5° / 35° / 72.5° | |
| V  |  |  |  |  | |
| 刀片形状 Insert Shape | DWLN PVLN 95° / 80° | | | | |
| W  |  | | | | |
| 刀片形状 Insert Shape | SCLCR SCLCL 95° / 80° | SCMCN 50° / 80° / 50° | SCLC 长型 95° / 80° | | |
| C  |  |  |  | | |

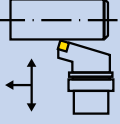
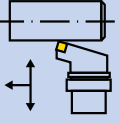
车刀刀体 HSK-T
车刀刀体 HSK-T 产品总览

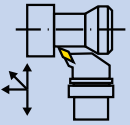
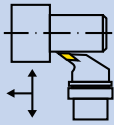
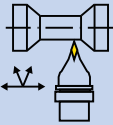
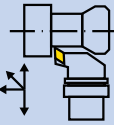
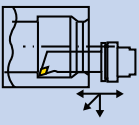
| 刀片形状 Insert Shape | SDHCR SDHCL 107.5° / 55° | SDNCN 62.5°/55°/62.5° | SDJCR SDJCL 93° / 55° | SDUCR SDUCL 93° / 55° | SDQC 长型 107.5° / 55° |
|---------------------------------------------------------------------------------------|------------------------------------------------------------------------------------|------------------------------------------------------------------------------------|------------------------------------------------------------------------------------|--------------------------------------------------------------------------------------|--------------------------------------------------------------------------------------|
| D  |  |  |  |  |  |
| 刀片形状 Insert Shape | SSBCR SSBCL 75° / 90° | SSSCR SSSCL 45° / 90° | | | |
| S  |  |  | | | |
| 刀片形状 Insert Shape | SVPB SVPC 117.5° / 35° | SVUB SVUC 93° / 35° | SVVB SVVC 72.5° / 35° / 72.5° | SVJB SVJC 93° / 35° | SVQC 长型 107.5° / 55° |
| V  |  |  |  |  |  |

HSK

HSK-T TOOLING SYSTEM

HSK-T 工具系统

| | |
|---------------------------|------|
| Boring Bar Holder | F.58 |
| 复合刀具, 镗孔刀夹 | |
| Facing | F.59 |
| 复合车刀座, 端面加工 | |
| External and Facing..... | F.59 |
| 复合车刀座, 外径端面加工 | |
| External and Cut-off..... | F.60 |
| 复合车刀座, 外径切断加工 | |
| External and Facing..... | F.60 |
| 复合车刀座, 外径端面加工 | |

| | |
|-------------------------------|------|
| Turning Tool, Negative..... | F.61 |
| 车刀刀体, 负前角刀片 | |
| DCLNR DCLNL 95°/80°..... | F.61 |
| PCLNR PCLNL 95° /80° | F.61 |
| DCMNN 50°/80°/50°..... | F.62 |
| PCMNN 50°/80°/50°..... | F.62 |
| DDJNR DDJNL 55°/93°..... | F.63 |
| PDJNR PDJNL 55°/93°..... | F.63 |
| DDNNN 62.5°/55°/62.5°..... | F.64 |
| PDNNN 62.5°/55°/62.5°..... | F.64 |
| DDUNR DDUNL 93°/55°..... | F.64 |
| PDUNR PDUNL 93°/55°..... | F.65 |
| DSBNR DSBNL 90°/75°..... | F.65 |
| PSBNR PSBNL 90°/75°..... | F.65 |
| DSSNR DSSNL 45°/90°..... | F.66 |
| PSSNR PSSNL 45°/90°..... | F.66 |
| DVPNR DVPNL 117.5°/35°..... | F.66 |
| DVUNR DVUNL 93°/35°..... | F.67 |
| DVVNN 72.5°/35°/72.5°..... | F.67 |
| DVJNR DVJNL 93°/35°..... | F.67 |
| DWLNR DWLNL 95°/80°..... | F.68 |
| PWLNR PWLNL 95°/80°..... | F.68 |

| | |
|-----------------------------------------------|------|
| Turning Tool, Positive..... | F.69 |
| 车刀刀体, 正前角刀片 | |
| SCLCR SCLCL 95°/80°..... | F.69 |
| SCMCN 50°/80°/50°..... | F.69 |
| SDQCR SDQCL 107.5°/55°..... | F.69 |
| SDNCN 62.5°/55°/62.5°..... | F.69 |
| SDJCR SDJCL 93°/55°..... | F.70 |
| SDUCR SDUCL 93°/55°..... | F.70 |
| SSBCR SSBCL 75°/90°..... | F.70 |
| SSSCR SSSCL 45°/90°..... | F.71 |
| SVPBR SVPBL SVPCR SVPCL 117.5°/35°..... | F.71 |
| SVUBR SVUBL SVUCR SVUCL 93°/35°..... | F.72 |
| SVWBN SVWCN 72.5°/35°/72.5°..... | F.72 |
| SVJBR SVJBL SVJCR SVJCL 93°/35°..... | F.73 |

| | |
|----------------------------------|------|
| 长型 PCLNR PCLNL 95° /80° | F.74 |
| 长型 PDQNR PDQNL 107.5°/55°..... | F.74 |
| 长型 DDQNR DDQNL 107.5°/55°..... | F.75 |
| 长型 SCLCR SCLCL 95°/80°..... | F.75 |
| 长型 SVQCR SVQCL 107.5°/55°..... | F.76 |



HSK-T Boring Bar Holder

复合刀具, 镗孔刀夹

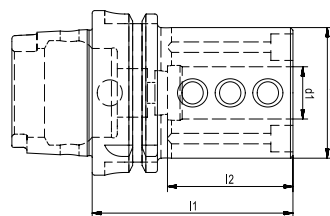

| Size | d1 | d2 | l1 | l2 |
|-----------------|----|----|-----|----|
| HSK40TAX-E2-08 | 8 | 32 | 60 | 37 |
| HSK40TAX-E2-10 | 10 | 34 | 60 | 37 |
| HSK40TAX-E2-12 | 12 | 36 | 65 | 40 |
| HSK40TAX-E2-16 | 16 | 40 | 70 | 42 |
| HSK40TAX-E2-20 | 20 | 45 | 70 | 42 |
| | | | | |
| HSK50TAX-E2-10 | 10 | 38 | 75 | 45 |
| HSK50TAX-E2-12 | 12 | 40 | 75 | 45 |
| HSK50TAX-E2-16 | 16 | 45 | 80 | 50 |
| HSK50TAX-E2-20 | 20 | 50 | 80 | 47 |
| HSK50TAX-E2-25 | 25 | 55 | 85 | 50 |
| | | | | |
| HSK63TAX-E2-06 | 6 | 30 | 65 | 40 |
| HSK63TAX-E2-08 | 8 | 32 | 70 | 40 |
| HSK63TAX-E2-10 | 10 | 38 | 75 | 45 |
| HSK63TAX-E2-12 | 12 | 40 | 75 | 45 |
| HSK63TAX-E2-16 | 16 | 45 | 80 | 50 |
| HSK63TAX-E2-20 | 20 | 50 | 80 | 50 |
| HSK63TAX-E2-25 | 25 | 55 | 85 | 52 |
| HSK63TAX-E2-32 | 32 | 72 | 108 | 60 |
| HSK63TAX-E2-40 | 40 | 80 | 120 | 72 |
| | | | | |
| HSK100TAX-E2-16 | 16 | 45 | 85 | 48 |
| HSK100TAX-E2-20 | 20 | 50 | 85 | 48 |
| HSK100TAX-E2-25 | 25 | 55 | 85 | 48 |
| HSK100TAX-E2-32 | 32 | 72 | 95 | 58 |
| HSK100TAX-E2-40 | 40 | 80 | 110 | 73 |
| HSK100TAX-E2-50 | 50 | 90 | 120 | 82 |

HSK·T Turning Tools for Facing 复合车刀座, 端面加工

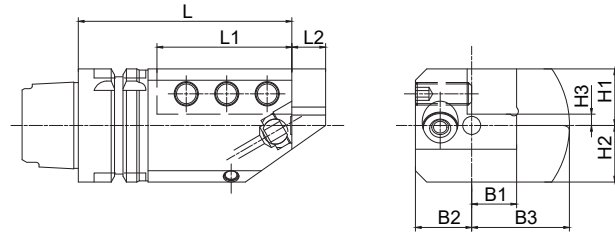

| Size | L | L1 | L2 | B1 | B2 | B3 | H1 | H2 | H3 | G |
|----------------------|-----|-----|----|----|----|------|----|----|----|-----|
| HSK50T-SBV2020R-105 | 105 | 60 | 15 | 20 | 25 | 43.5 | 25 | 25 | 5 | M10 |
| HSK50T-SBV2020L-105 | 105 | 60 | 15 | 20 | 25 | 43.5 | 25 | 25 | 5 | M10 |
| HSK63T-SBV2020R-105 | 105 | 60 | 15 | 20 | 32 | 43.5 | 33 | 32 | 13 | M10 |
| HSK63T-SBV2020L-105 | 105 | 60 | 15 | 20 | 32 | 43.5 | 33 | 32 | 13 | M10 |
| HSK63T-SBV2525R-115 | 115 | 70 | 20 | 25 | 32 | 45 | 30 | 30 | 5 | M12 |
| HSK63T-SBV2525L-115 | 115 | 70 | 20 | 25 | 32 | 45 | 30 | 30 | 5 | M12 |
| HSK100T-SBV2525R-160 | 160 | 110 | 20 | 25 | 37 | 59 | 48 | 43 | 23 | M12 |
| HSK100T-SBV2525L-150 | 150 | 110 | 20 | 25 | 37 | 59 | 48 | 43 | 23 | M12 |
| HSK100T-SBV3232R-150 | 150 | 110 | 20 | 32 | 40 | 68.5 | 45 | 43 | 15 | M14 |
| HSK100T-SBV3232L-150 | 150 | 110 | 20 | 32 | 40 | 68.5 | 45 | 43 | 15 | M14 |

HSK·T Turning Tools for External and Facing 复合车刀座, 外径端面加工

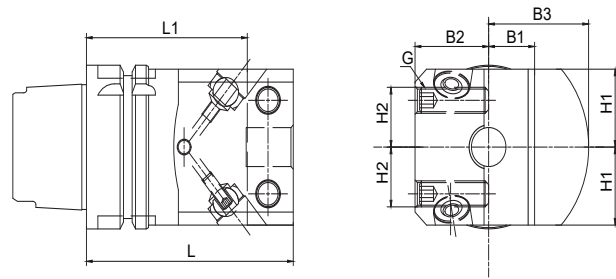
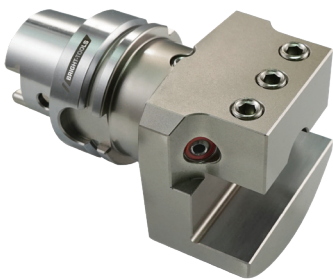

| Size | L | L1 | B1 | B2 | B3 | H1 | H2 | G |
|----------------------|-----|-----|----|----|------|------|------|-----|
| HSK50T-SBH2020N-100 | 100 | 80 | 20 | 25 | 43.5 | 27.5 | - | M10 |
| HSK50T-SBH2020N-130 | 130 | 110 | 20 | 25 | 43.5 | 27.5 | - | M10 |
| HSK63T-SBH2020N-100 | 100 | 80 | 20 | 32 | 43.5 | 30 | - | M10 |
| HSK63T-SBH2525N-90 | 90 | 75 | 25 | 32 | 53 | 40.5 | 29.5 | M12 |
| HSK63T-SBH2525N-120 | 120 | 105 | 25 | 32 | 53 | 40.5 | 29.5 | M12 |
| HSK100T-SBH2525N-115 | 115 | 90 | 25 | 32 | 59 | 48 | 37 | M12 |
| HSK100T-SBH2525N-160 | 160 | 135 | 25 | 32 | 59 | 48 | 37 | M12 |
| HSK100T-SBH3232N-115 | 115 | 85 | 32 | 40 | 68.5 | 57 | 43 | M14 |

HSK·T Turning Tools for External and Cut-off

复合车刀座, 外径切断加工

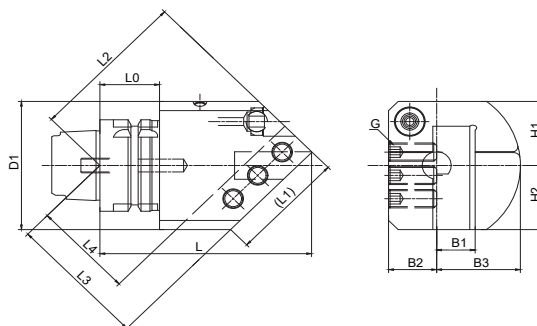

| Size | L | L1 | L2 | L3 | L4 | D1 | B1 | B2 | B3 | H1 | H2 | G |
|----------------------|-----|----|-------|------|------|----|----|----|------|----|----|-----|
| HSK50T-SBN2020R-120 | 120 | 60 | 83.1 | 72.8 | 52.8 | - | 20 | 25 | 43.5 | 35 | 35 | M10 |
| HSK50T-SBN2020L-120 | 120 | 60 | 83.1 | 72.8 | 52.8 | - | 20 | 25 | 43.5 | 35 | 35 | M10 |
| HSK63T-SBN2020R-120 | 120 | 60 | 83.1 | 72.8 | 52.8 | - | 20 | 32 | 43.5 | 35 | 35 | M10 |
| HSK63T-SBN2020L-120 | 120 | 60 | 83.1 | 72.8 | 52.8 | - | 20 | 32 | 43.5 | 35 | 35 | M10 |
| HSK63T-SBN2525R-120 | 120 | 70 | 85.2 | 70.8 | 45.8 | 90 | 25 | 32 | 53 | 39 | 39 | M12 |
| HSK63T-SBN2525L-120 | 120 | 70 | 85.2 | 70.8 | 45.8 | 90 | 25 | 32 | 53 | 39 | 39 | M12 |
| HSK100T-SBN2525R-145 | 145 | 70 | 102.9 | 88.5 | 63.5 | - | 25 | 32 | 59 | 43 | 43 | M12 |
| HSK100T-SBN2525L-145 | 145 | 70 | 102.9 | 88.5 | 63.5 | - | 25 | 32 | 59 | 43 | 43 | M12 |
| HSK100T-SBN3232R-150 | 150 | 85 | 109.9 | 89 | 59 | - | 32 | 37 | 68.5 | 48 | 43 | M14 |
| HSK100T-SBN3232L-150 | 150 | 85 | 109.9 | 89 | 59 | - | 32 | 37 | 68.5 | 48 | 43 | M14 |

HSK·T Turning Tools for External and Facing

复合车刀座, 外径端面加工

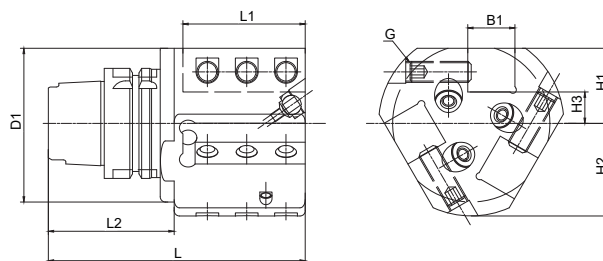
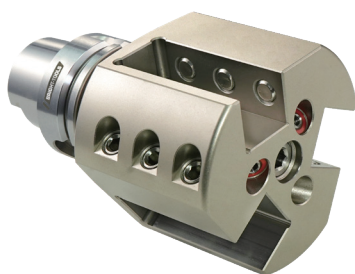

| Size | L | L1 | L2 | D1 | B1 | H1 | H2 | H3 | G |
|----------------------|-----|-----|----|----|----|----|------|----|-----|
| HSK50T-SBT2020R-105 | 105 | 60 | - | - | 20 | 35 | 43.5 | 15 | M10 |
| HSK50T-SBT2020L-105 | 105 | 60 | - | - | 20 | 35 | 43.5 | 15 | M10 |
| | | | - | - | 20 | 35 | 43.5 | 15 | M10 |
| HSK63T-SBT2020R-105 | 105 | 60 | - | - | 20 | 35 | 43.5 | 15 | M10 |
| HSK63T-SBT2020L-105 | 105 | 60 | | | | | | | |
| HSK63T-SBT2525R-125 | 125 | 70 | 40 | 90 | 25 | 43 | 53 | 18 | M12 |
| HSK63T-SBT2525L-125 | 125 | 70 | 40 | 90 | 25 | 43 | 53 | 18 | M12 |
| HSK100T-SBT2525R-160 | 160 | 110 | - | - | 25 | 48 | 59 | 23 | M12 |
| HSK100T-SBT2525L-160 | 160 | 110 | - | - | 25 | 48 | 59 | 23 | M12 |

HSK-T Turning Tool DCLNR | DCLNL 95°/80° 负前角刀片

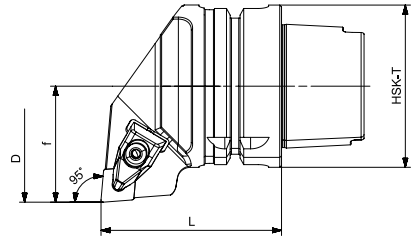
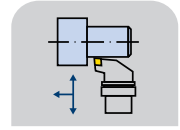

| Size | f | D min | L | Direction | Inserts N. |
|------------------------|----|-------|-----|-----------|------------|
| HSK63T-DCLNR-45070-12 | 45 | 80 | 70 | R | CN..1204.. |
| HSK63T-DCLNL-45070-12 | 45 | 80 | 70 | L | CN..1204.. |
| HSK63T-DCLNR-45070-16 | 45 | 80 | 70 | R | CN..1606.. |
| HSK63T-DCLNL-45070-16 | 45 | 80 | 70 | L | CN..1606.. |
| HSK100T-DCLNR-63100-12 | 63 | 120 | 100 | R | CN..1204.. |
| HSK100T-DCLNL-63100-12 | 63 | 120 | 100 | L | CN..1204.. |
| HSK100T-DCLNR-63100-16 | 63 | 120 | 100 | R | CN..1606.. |
| HSK100T-DCLNL-63100-16 | 63 | 120 | 100 | L | CN..1606.. |

HSK

HSK-T Turning Tool PCLNR | PCLNL 95°/80° 负前角刀片

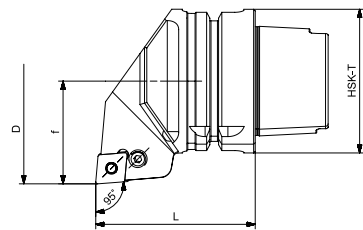
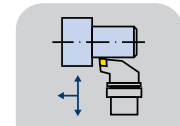

| Size | f | D min | L | Direction | Inserts N. |
|------------------------|----|-------|-----|-----------|------------|
| HSK63T-PCLNR-45070-12 | 45 | 80 | 70 | R | CN..1204.. |
| HSK63T-PCLNL-45070-12 | 45 | 80 | 70 | L | CN..1204.. |
| HSK63T-PCLNR-45070-16 | 45 | 80 | 70 | R | CN..1606.. |
| HSK63T-PCLNL-45070-16 | 45 | 80 | 70 | L | CN..1606.. |
| HSK100T-PCLNR-63100-12 | 63 | 120 | 100 | R | CN..1204.. |
| HSK100T-PCLNL-63100-12 | 63 | 120 | 100 | L | CN..1204.. |
| HSK100T-PCLNR-63100-16 | 63 | 120 | 100 | R | CN..1606.. |
| HSK100T-PCLNL-63100-16 | 63 | 120 | 100 | L | CN..1606.. |
| HSK100T-PCLNR-63100-19 | 63 | 120 | 100 | R | CN..1906.. |
| HSK100T-PCLNL-63100-19 | 63 | 120 | 100 | L | CN..1906.. |

HSK-T Turning Tool DCMNN 50°/80°/50° 负前角刀片

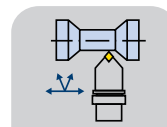
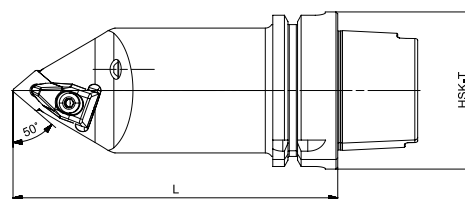

| Size | L | Direction | Inserts N. |
|----------------------|-----|-----------|------------|
| HSK63T-DCMNN-100-12 | 100 | N | CN..1204.. |
| HSK63T-DCMNN-130-12 | 130 | N | CN..1204.. |
| HSK63T-DCMNN-100-16 | 100 | N | CN..1606.. |
| HSK63T-DCMNN-130-16 | 130 | N | CN..1606.. |
| HSK100T-DCMNN-125-12 | 125 | N | CN..1204.. |
| HSK100T-DCMNN-125-16 | 125 | N | CN..1606.. |

HSK

HSK-T Turning Tool PCMNN 50°/80°/50° 负前角刀片

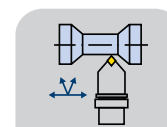
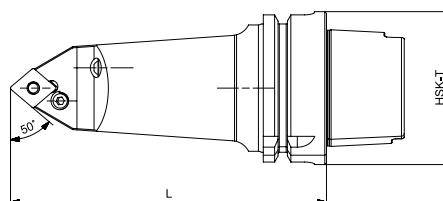

| Size | L | Direction | Inserts N. |
|----------------------|-----|-----------|------------|
| HSK63T-PCMNN-100-12 | 100 | N | CN..1204.. |
| HSK63T-PCMNN-130-12 | 130 | N | CN..1204.. |
| HSK63T-PCMNN-100-16 | 100 | N | CN..1606.. |
| HSK63T-PCMNN-130-16 | 130 | N | CN..1606.. |
| HSK100T-PCMNN-125-12 | 125 | N | CN..1204.. |
| HSK100T-PCMNN-125-16 | 125 | N | CN..1606.. |

HSK-T Turning Tool DDJNR | DDJNL 55°/93° 负前角刀片

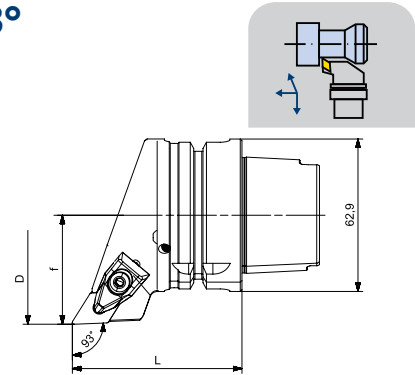

| Size | f | L | Direction | Inserts N. |
|------------------------|----|-----|-----------|------------|
| HSK63T-DDJNR-45075-15 | 45 | 70 | R | DN..1506.. |
| HSK63T-DDJNL-45075-15 | 45 | 70 | L | DN..1506.. |
| HSK100T-DDJNR-63100-15 | 63 | 100 | R | DN..1506.. |
| HSK100T-DDJNL-63100-15 | 63 | 100 | L | DN..1506.. |



HSK-T Turning Tool PDJNR | PDJNL 55°/93° 负前角刀片

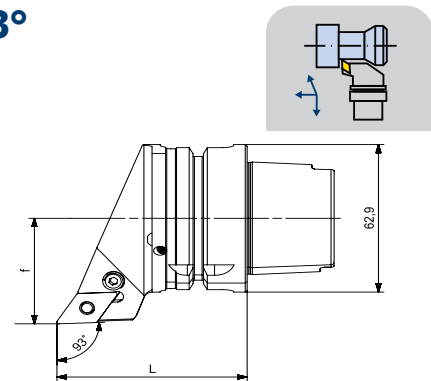

| Size | f | L | Direction | Inserts N. |
|------------------------|----|-----|-----------|------------|
| HSK63T-PDJNR-45070-15 | 45 | 70 | R | DN..1506.. |
| HSK63T-PDJNL-45070-15 | 45 | 70 | L | DN..1506.. |
| HSK100T-PDJNR-63100-15 | 63 | 100 | R | DN..1506.. |
| HSK100T-PDJNL-63100-15 | 63 | 100 | L | DN..1506.. |

HSK-T Turning Tool DDNNN 62.5°/55°/62.5°

负前角刀片

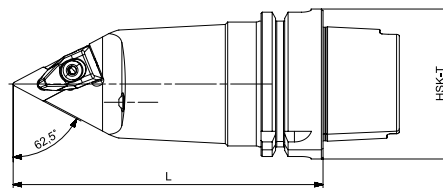
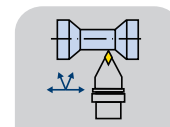

| Size | L | Direction | Inserts N. |
|----------------------|-----|-----------|------------|
| HSK63T-DDNNN-100-15 | 100 | N | DN..1506.. |
| HSK63T-DDNNN-130-15 | 130 | N | DN..1506.. |
| HSK100T-DDNNN-125-15 | 125 | N | DN..1506.. |

HSK

HSK-T Turning Tool PDNNN 62.5°/55°/62.5°

负前角刀片

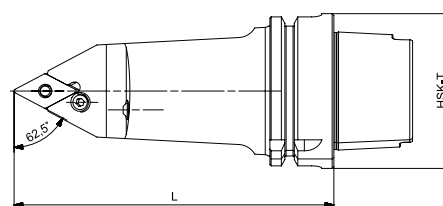
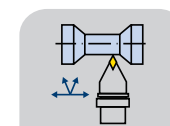

| Size | L | Direction | Inserts N. |
|----------------------|-----|-----------|------------|
| HSK63T-PDNNN-100-15 | 100 | N | DN..1506.. |
| HSK63T-PDNNN-130-15 | 130 | N | DN..1506.. |
| HSK100T-PDNNN-125-15 | 125 | N | DN..1506.. |

HSK-T Turning Tool DDUNR | DDUNL 93°/55°

负前角刀片

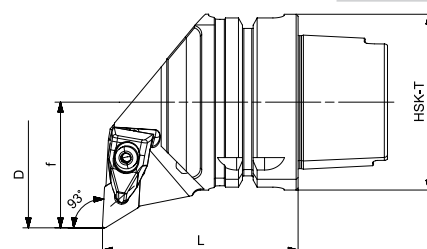
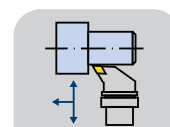

| Size | f | D min | L | Direction | Inserts N. |
|------------------------|----|-------|-----|-----------|------------|
| HSK63T-DDUNR-45070-15 | 45 | 80 | 70 | R | DN..1506.. |
| HSK63T-DDUNL-45070-15 | 45 | 80 | 70 | L | DN..1506.. |
| HSK100T-DDUNR-63100-15 | 63 | 120 | 100 | R | DN..1506.. |
| HSK100T-DDUNL-63100-15 | 63 | 120 | 100 | L | DN..1506.. |

HSK-T Turning Tool PDUNR | PDUNL 93°/55°

负前角刀片

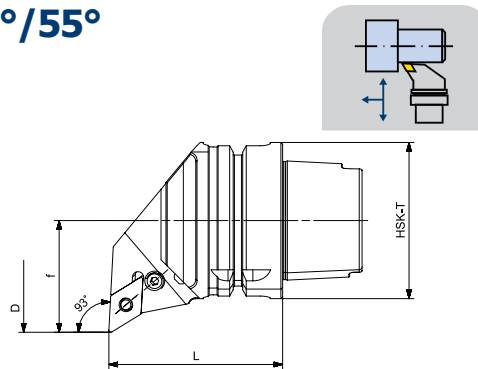

| Size | f | D min | L | Direction | Inserts N. |
|------------------------|----|-------|-----|-----------|------------|
| HSK63T-PDUNR-45070-15 | 45 | 80 | 70 | R | DN..1506.. |
| HSK63T-PDUNL-45070-15 | 45 | 80 | 70 | L | DN..1506.. |
| HSK100T-PDUNR-63100-15 | 63 | 120 | 100 | R | DN..1506.. |
| HSK100T-PDUNL-63100-15 | 63 | 120 | 100 | L | DN..1506.. |

HSK-T Turning Tool DSBNR | DSBNL 90°/75°

负前角刀片

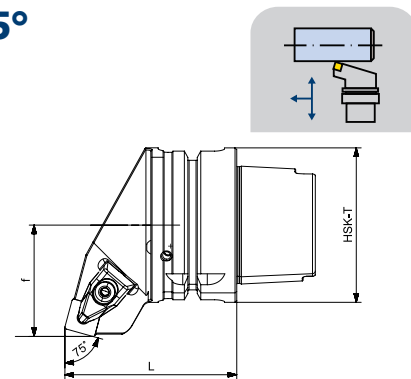

| Size | f | L | Direction | Inserts N. |
|------------------------|----|-----|-----------|------------|
| HSK63T-DSBNR-45070-12 | 45 | 70 | R | SN..1204.. |
| HSK63T-DSBNL-45070-12 | 45 | 70 | L | SN..1204.. |
| HSK100T-DSBNR-63100-12 | 63 | 100 | R | SN..1204.. |
| HSK100T-DSBNL-63100-12 | 63 | 100 | L | SN..1204.. |

HSK-T Turning Tool PSBNR | PSBNL 90°/75°

负前角刀片

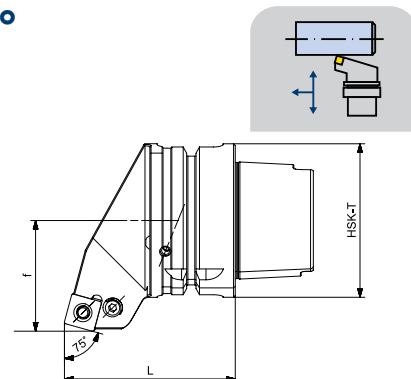

| Size | f | L | Direction | Inserts N. |
|------------------------|----|-----|-----------|------------|
| HSK63T-PSBNR-45070-12 | 45 | 70 | R | SN..1204.. |
| HSK63T-PSBNL-45070-12 | 45 | 70 | L | SN..1204.. |
| HSK100T-PSBNR-63100-12 | 63 | 100 | R | SN..1204.. |
| HSK100T-PSBNL-63100-12 | 63 | 100 | L | SN..1204.. |

HSK

HSK-T Turning Tool DSSNR | DSSNL 45°/90°

负前角刀片

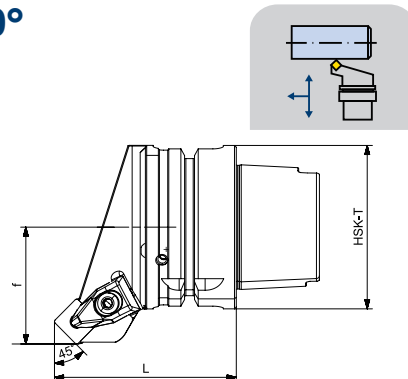

| Size | f | D min | L | Direction | Inserts N. |
|------------------------|----|-------|-----|-----------|------------|
| HSK63T-DSSNR-45070-12 | 45 | - | 70 | R | SN..1204.. |
| HSK63T-DSSNL-45070-12 | 45 | - | 70 | L | SN..1204.. |
| HSK100T-DSSNR-63100-12 | 63 | - | 100 | R | SN..1204.. |
| HSK100T-DSSNL-63100-12 | 63 | - | 100 | L | SN..1204.. |

HSK

HSK-T Turning Tool PSSNR | PSSNL 45°/90°

负前角刀片

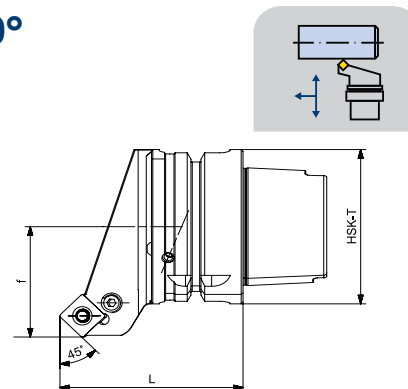

| Size | f | L | Direction | Inserts N. |
|------------------------|----|-----|-----------|------------|
| HSK63T-PSSNR-45070-12 | 45 | 70 | R | SN..1204.. |
| HSK63T-PSSNL-45070-12 | 45 | 70 | L | SN..1204.. |
| HSK100T-PSSNR-63100-12 | 63 | 100 | R | SN..1204.. |
| HSK100T-PSSNL-63100-12 | 63 | 100 | L | SN..1204.. |

HSK-T Turning Tool DVPNR | DVPNL 117.5°/35°

负前角刀片

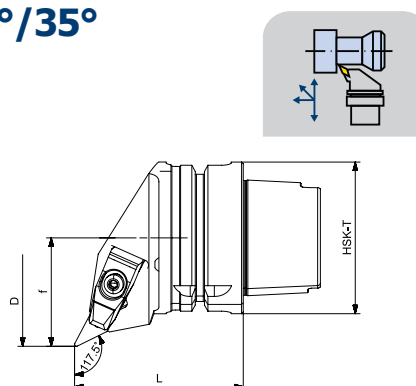

| Size | f | D min | L | Direction | Inserts N. |
|------------------------|----|-------|-----|-----------|------------|
| HSK63T-DVPNR-45070-16 | 45 | 80 | 70 | R | VN..1604.. |
| HSK63T-DVPNL-45070-16 | 45 | 80 | 70 | L | VN..1604.. |
| HSK100T-DVPNR-63100-16 | 63 | 120 | 100 | R | VN..1604.. |
| HSK100T-DVPNL-63100-16 | 63 | 120 | 100 | L | VN..1604.. |

HSK-T Turning Tool DVUNR | DVUNL 93°/35°

负前角刀片

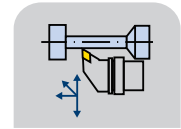
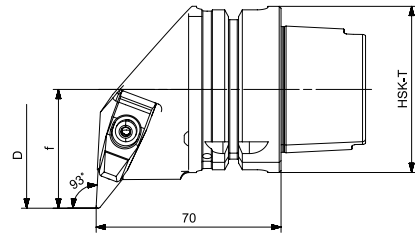

| Size | f | D min | L | Direction | Inserts N. |
|------------------------|----|-------|-----|-----------|------------|
| HSK63T-DVUNR-45070-16 | 45 | 80 | 70 | R | VN..1604.. |
| HSK63T-DVUNL-45070-16 | 45 | 80 | 70 | L | VN..1604.. |
| HSK100T-DVUNR-63100-16 | 63 | 120 | 100 | R | VN..1604.. |
| HSK100T-DVUNL-63100-16 | 63 | 120 | 100 | L | VN..1604.. |

HSK-T Turning Tool DVVNN 72.5°/35°/72.5°

负前角刀片

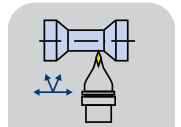
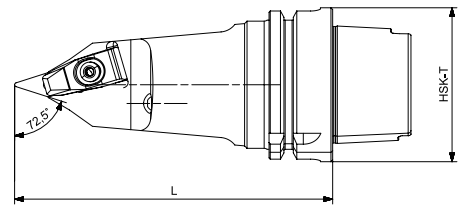

| Size | L | Direction | Inserts N. |
|----------------------|-----|-----------|------------|
| HSK63T-DVVNN-100-16 | 100 | N | VN..1604.. |
| HSK63T-DVVNN-130-16 | 130 | N | VN..1604.. |
| HSK100T-DVVNN-125-16 | 125 | N | VN..1604.. |

HSK-T Turning Tool DVJNR | DVJNL 93°/35°

负前角刀片

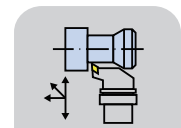
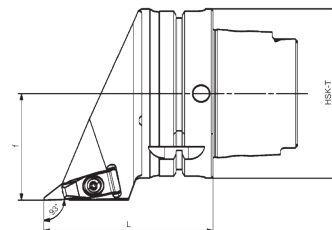

| Size | f | D min | L | Direction | Inserts N. |
|------------------------|----|-------|-----|-----------|------------|
| HSK100T-DVJNR16-100-63 | 63 | - | 100 | R | VN..1604.. |
| HSK100T-DVJNL16-100-63 | 63 | - | 100 | L | VN..1604.. |

HSK-T Turning Tool DWLNR | DWLNL 95°/80°

负前角刀片

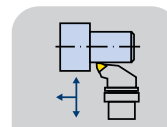
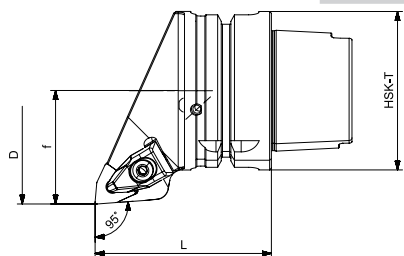

| Size | f | D min | L | Direction | Inserts N. |
|-----------------------|----|-------|-----|-----------|------------|
| HSK63T-DWLNR-45070-8 | 45 | 80 | 70 | R | WN..0804.. |
| HSK63T-DWLNL-45070-8 | 45 | 80 | 70 | L | WN..0804.. |
| HSK100T-DWLNR-63100-8 | 63 | 120 | 100 | R | WN..0804.. |
| HSK100T-DWLNL-63100-8 | 63 | 120 | 100 | L | WN..0804.. |

HSK

HSK-T Turning Tool PWLNR | PWLNL 95°/80°

负前角刀片

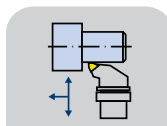
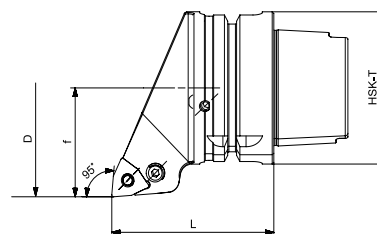

| Size | f | D min | L | Direction | Inserts N. |
|-----------------------|----|-------|-----|-----------|------------|
| HSK63T-PWLNR-45070-8 | 45 | 80 | 70 | R | WN..0804.. |
| HSK63T-PWLNL-45070-8 | 45 | 80 | 70 | L | WN..0804.. |
| HSK100T-PWLNR-63100-8 | 63 | 120 | 100 | R | WN..0804.. |
| HSK100T-PWLNL-63100-8 | 63 | 120 | 100 | L | WN..0804.. |

HSK-T Turning Tool SCLCR | SCLCL 95°/80°

正前角刀片

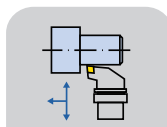
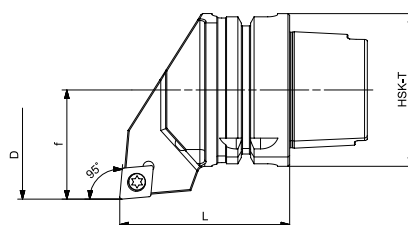

| Size | f | D min | L | Direction | Inserts N. |
|------------------------|----|-------|-----|-----------|------------|
| HSK63T-SCLCR-45070-12 | 45 | 80 | 70 | R | CC..1204.. |
| HSK63T-SCLCL-45070-12 | 45 | 80 | 70 | L | CC..1204.. |
| HSK100T-SCLCR-63100-12 | 63 | 120 | 100 | R | CC..1204.. |
| HSK100T-SCLCL-63100-12 | 63 | 120 | 100 | L | CC..1204.. |

HSK-T Turning Tool SCMCN 50°/80°/50° 正前角刀片

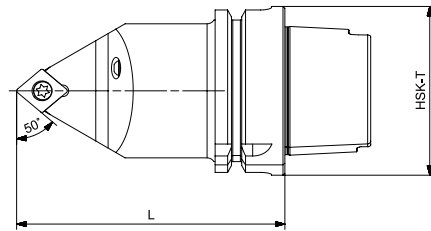
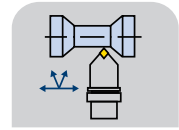

| Size | L | Direction | Inserts N. |
|----------------------|-----|-----------|------------|
| HSK63T-SCMCN-100-12 | 100 | N | CC..1204.. |
| HSK63T-SCMCN-130-12 | 130 | N | CC..1204.. |
| HSK100T-SCMCN-125-12 | 125 | N | CC..1204.. |

HSK-T Turning Tool SDQCR | SDQCL 107.5°/55° 正前角刀片

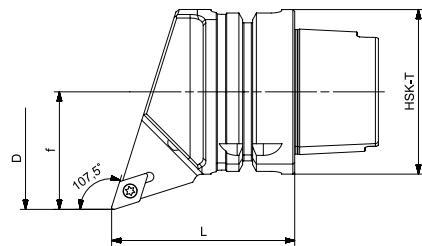
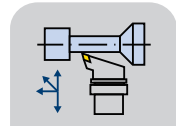

| Size | f | D min | L | Direction | Inserts N. |
|------------------------|----|-------|-----|-----------|------------|
| HSK63T-SDQCR-45070-11 | 45 | 80 | 70 | R | DC..11T3.. |
| HSK63T-SDQCL-45070-11 | 45 | 80 | 70 | L | DC..11T3.. |
| HSK100T-SDQCR-63100-11 | 63 | 120 | 100 | R | DC..11T3.. |
| HSK100T-SDQCL-63100-11 | 63 | 120 | 100 | L | DC..11T3.. |

HSK-T Turning Tool SDNCN 62.5°/55°/62.5° 正前角刀片

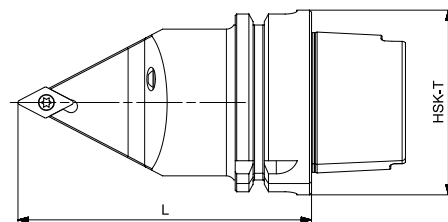
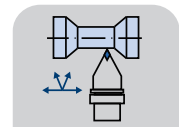

| Size | L | Direction | Inserts N. |
|----------------------|-----|-----------|------------|
| HSK63T-SDNCN-100-11 | 100 | N | DC..11T3.. |
| HSK63T-SDNCN-130-11 | 130 | N | DC..11T3.. |
| HSK100T-SDNCN-125-11 | 125 | N | DC..11T3.. |

HSK-T Turning Tool SDJCR | SDJCL 93°/55°

正前角刀片

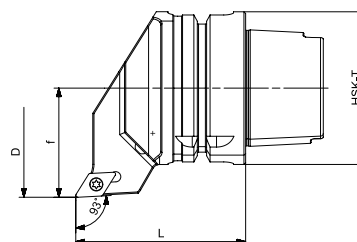
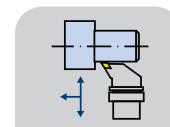

| Size | f | D min | L | Direction | Inserts N. |
|------------------------|----|-------|-----|-----------|------------|
| HSK63T-SDJCR-45070-11 | 45 | 80 | 70 | R | DC..11T3.. |
| HSK63T-SDJCL-45070-11 | 45 | 80 | 70 | L | DC..11T3.. |
| HSK100T-SDJCR-63100-11 | 63 | 120 | 100 | R | DC..11T3.. |
| HSK100T-SDJCL-63100-11 | 63 | 120 | 100 | L | DC..11T3.. |

HSK

HSK-T Turning Tool SDUCR | SDUCL 93°/55°

正前角刀片

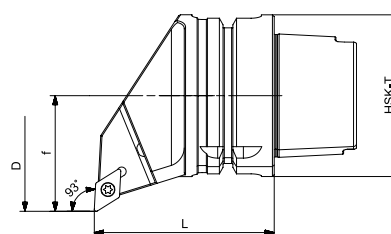
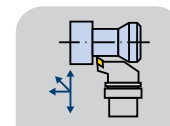

| Size | f | D | L | Direction | Inserts N. |
|------------------------|----|-----|-----|-----------|------------|
| HSK63T-SDUCR-45070-11 | 45 | 80 | 70 | R | DC..11T3.. |
| HSK63T-SDUCL-45070-11 | 45 | 80 | 70 | L | DC..11T3.. |
| HSK100T-SDUCR-63100-11 | 63 | 120 | 100 | R | DC..11T3.. |
| HSK100T-SDUCL-63100-11 | 63 | 120 | 100 | L | DC..11T3.. |

HSK-T Turning Tool SSBCR | SSBCL 75°/90°

正前角刀片

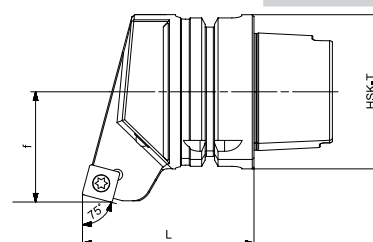
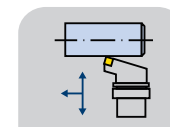

| Size | f | L | Direction | Inserts N. |
|------------------------|----|-----|-----------|------------|
| HSK63T-SSBCR-45070-12 | 45 | 70 | R | SC..1204.. |
| HSK63T-SSBCL-45070-12 | 45 | 70 | L | SC..1204.. |
| HSK100T-SSBCR-63100-12 | 63 | 100 | R | SC..1204.. |
| HSK100T-SSBCL-63100-12 | 63 | 100 | L | SC..1204.. |

HSK-T Turning Tool SSSCR | SSSCL 45°/90° 正前角刀片

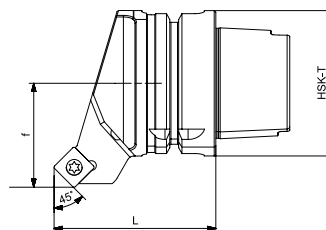
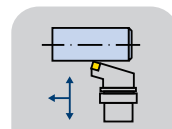

| Size | f | L | Direction | Inserts N. |
|------------------------|----|-----|-----------|------------|
| HSK63T-SSSCR-45070-12 | 45 | 70 | R | SC..1204.. |
| HSK63T-SSSCL-45070-12 | 45 | 70 | L | SC..1204.. |
| HSK100T-SSSCR-63100-12 | 63 | 100 | R | SC..1204.. |
| HSK100T-SSSCL-63100-12 | 63 | 100 | L | SC..1204.. |

HSK-T Turning Tool SVPBR | SVPBL | SVPCR | SVPCL 117.5°/35° 正前角刀片

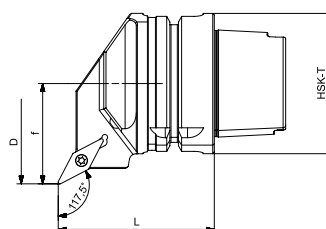
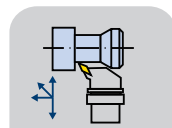

| Size | f | D min | L | Direction | Inserts N. |
|------------------------|----|-------|-----|-----------|------------|
| HSK63T-SVPBR-45070-16 | 45 | 80 | 70 | R | VB..1604.. |
| HSK63T-SVPBL-45070-16 | 45 | 80 | 70 | L | VB..1604.. |
| HSK63T-SVPCR-45070-16 | 45 | 80 | 70 | R | VC..1604.. |
| HSK63T-SVPCL-45070-16 | 45 | 80 | 70 | L | VC..1604.. |
| HSK100T-SVPBR-63100-16 | 63 | 120 | 100 | R | VB..1604.. |
| HSK100T-SVPBL-63100-16 | 63 | 120 | 100 | L | VB..1604.. |
| HSK100T-SVPCR-63100-16 | 63 | 120 | 100 | R | VC..1604.. |
| HSK100T-SVPCL-63100-16 | 63 | 120 | 100 | L | VC..1604.. |

HSK

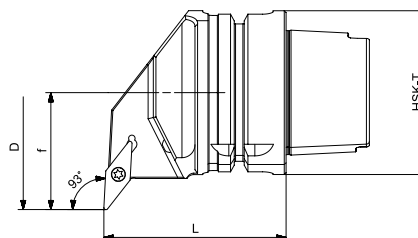
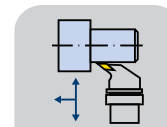
HSK-T Turning Tool SVUBR | SVUBL | SVUCR | SVUCL 93°/35°
正前角刀片

| Size | f | D min | L | Direction | Inserts N. |
|------------------------|----|-------|-----|-----------|------------|
| HSK63T-SVUBR-45070-16 | 45 | 80 | 70 | R | VB..1604.. |
| HSK63T-SVUBL-45070-16 | 45 | 80 | 70 | L | VB..1604.. |
| HSK63T-SVUCR-45070-16 | 45 | 80 | 70 | R | VC..1604.. |
| HSK63T-SVUCL-45070-16 | 45 | 80 | 70 | L | VC..1604.. |
| HSK100T-SVUBR-63100-16 | 63 | 120 | 100 | R | VB..1604.. |
| HSK100T-SVUBL-63100-16 | 63 | 120 | 100 | L | VB..1604.. |
| HSK100T-SVUCR-63100-16 | 63 | 120 | 100 | R | VC..1604.. |
| HSK100T-SVUCL-63100-16 | 63 | 120 | 100 | L | VC..1604.. |

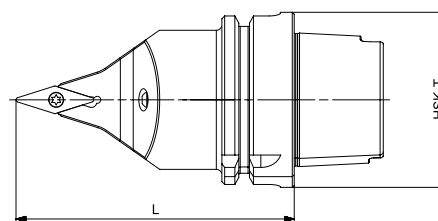
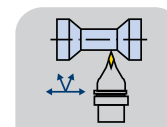
HSK
HSK-T Turning Tool SVVBN | SVVCN 72.5°/35°/72.5°
正前角刀片

| Size | L | Direction | Inserts N. |
|----------------------|-----|-----------|------------|
| HSK63T-SVVBN-100-16 | 100 | N | VB..1604.. |
| HSK63T-SVVBN-130-16 | 130 | N | VB..1604.. |
| HSK63T-SVVCN-100-16 | 100 | N | VC..1604.. |
| HSK63T-SVVCN-130-16 | 130 | N | VC..1604.. |
| HSK100T-SVVBN-125-16 | 125 | N | VB..1604.. |
| HSK100T-SVVCN-125-16 | 125 | N | VC..1604.. |

HSK-T Turning Tool SVJBR | SVJBL | SVJCR | SVJCL 93°/35°
正前角刀片

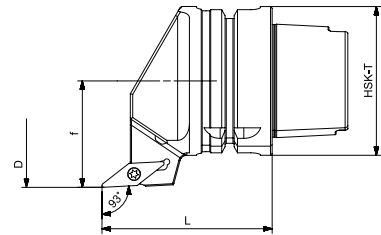
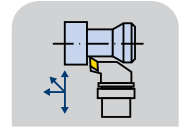

| Size | f | D min | L | Direction | Inserts N. |
|------------------------|----|-------|------|-----------|------------|
| HSK63T-SVJBR-45072-16 | 45 | 80 | 71.5 | R | VB..1604.. |
| HSK63T-SVJBL-45072-16 | 45 | 80 | 71.5 | L | VB..1604.. |
| HSK63T-SVJCR-45072-16 | 45 | 80 | 71.5 | R | VC..1604.. |
| HSK63T-SVJCL-45072-16 | 45 | 80 | 71.5 | L | VC..1604.. |
| HSK100T-SVJBR-63100-16 | 63 | 120 | 100 | R | VB..1604.. |
| HSK100T-SVJBL-63100-16 | 63 | 120 | 100 | L | VB..1604.. |
| HSK100T-SVJCR-63100-16 | 63 | 120 | 100 | R | VC..1604.. |
| HSK100T-SVJCL-63100-16 | 63 | 120 | 100 | L | VC..1604.. |

HSK

HSK-T Turning Tool DCLNR | DCLNL 95°/80°
负前角刀片

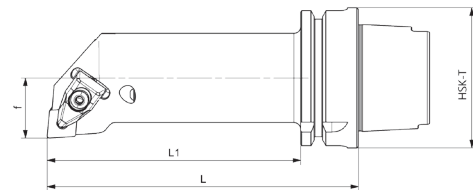
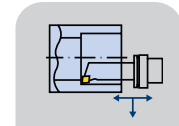

| Size | f | D min | L | L1 | Direction | Inserts N. |
|------------------------|----|-------|-----|-----|-----------|------------|
| HSK63T-DCLNR12-140-27 | 27 | 50 | 140 | 114 | R | CN..1204.. |
| HSK63T-DCLNL12-140-27 | 27 | 50 | 140 | 114 | L | CN..1204.. |
| HSK63T-DCLNR12-180-27 | 27 | 50 | 180 | 154 | R | CN..1204.. |
| HSK63T-DCLNL12-180-27 | 27 | 50 | 180 | 154 | L | CN..1204.. |
| HSK100T-DCLNR12-150-27 | 27 | 50 | 150 | 121 | R | CN..1204.. |
| HSK100T-DCLNL12-150-27 | 27 | 50 | 150 | 121 | L | CN..1204.. |
| HSK100T-DCLNR12-200-27 | 27 | 50 | 200 | 171 | R | CN..1204.. |
| HSK100T-DCLNL12-200-27 | 27 | 50 | 200 | 171 | L | CN..1204.. |
| HSK100T-DCLNR12-150-35 | 35 | 63 | 150 | 121 | R | CN..1204.. |
| HSK100T-DCLNL12-150-35 | 35 | 63 | 150 | 121 | L | CN..1204.. |
| HSK100T-DCLNR12-200-35 | 35 | 63 | 200 | 171 | R | CN..1204.. |
| HSK100T-DCLNL12-200-35 | 35 | 63 | 200 | 171 | L | CN..1204.. |

HSK-T Turning Tool 长型 PCLNR | PCLNL 95°/80°

负前角刀片

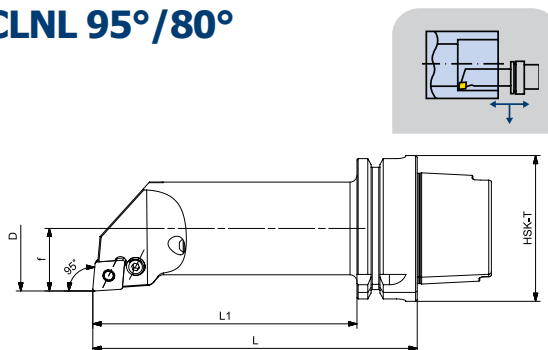

| Size | f | D min | L | L1 | Direction | Inserts N. |
|------------------------|----|-------|-----|-----|-----------|------------|
| HSK63T-PCLNR-27140-12 | 27 | 50 | 140 | 114 | R | CN..1204.. |
| HSK63T-PCLNL-27140-12 | 27 | 50 | 140 | 114 | L | CN..1204.. |
| HSK63T-PCLNR-27180-12 | 27 | 50 | 180 | 154 | R | CN..1204.. |
| HSK63T-PCLNL-27180-12 | 27 | 50 | 180 | 154 | L | CN..1204.. |
| HSK100T-PCLNR-27150-12 | 27 | 50 | 150 | 121 | R | CN..1204.. |
| HSK100T-PCLNL-27150-12 | 27 | 50 | 150 | 121 | L | CN..1204.. |
| HSK100T-PCLNR-27200-12 | 27 | 50 | 200 | 171 | R | CN..1204.. |
| HSK100T-PCLNL-27200-12 | 27 | 50 | 200 | 171 | L | CN..1204.. |
| HSK100T-PCLNR-35150-12 | 35 | 63 | 150 | 121 | R | CN..1204.. |
| HSK100T-PCLNL-35150-12 | 35 | 63 | 150 | 121 | L | CN..1204.. |
| HSK100T-PCLNR-35200-12 | 35 | 63 | 200 | 171 | R | CN..1204.. |
| HSK100T-PCLNL-35200-12 | 35 | 63 | 200 | 171 | L | CN..1204.. |

HSK

HSK-T Turning Tool 长型 PDQNR | PDQNL 107.5°/55°

负前角刀片

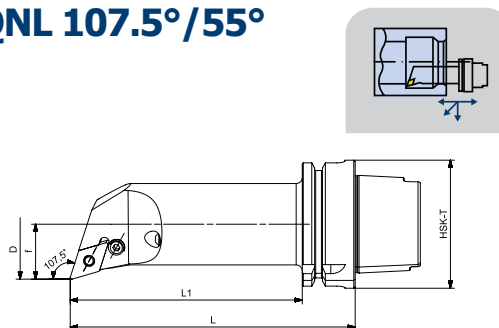

| Size | f | D min | L | L1 | Direction | Inserts N. |
|------------------------|----|-------|-----|-----|-----------|------------|
| HSK63T-PDQNR-27140-15 | 27 | 50 | 140 | 114 | R | DN..1506.. |
| HSK63T-PDQNL-27140-15 | 27 | 50 | 140 | 114 | L | DN..1506.. |
| HSK63T-PDQNR-27180-15 | 27 | 50 | 180 | 154 | R | DN..1506.. |
| HSK63T-PDQNL-27180-15 | 27 | 50 | 180 | 154 | L | DN..1506.. |
| HSK100T-PDQNR-27150-15 | 27 | 50 | 150 | 121 | R | DN..1506.. |
| HSK100T-PDQNL-27150-15 | 27 | 50 | 150 | 121 | L | DN..1506.. |
| HSK100T-PDQNR-27200-15 | 27 | 50 | 200 | 171 | R | DN..1506.. |
| HSK100T-PDQNL-27200-15 | 27 | 50 | 200 | 171 | L | DN..1506.. |
| HSK100T-PDQNR-35150-15 | 35 | 63 | 150 | 121 | R | DN..1506.. |
| HSK100T-PDQNL-35150-15 | 35 | 63 | 150 | 121 | L | DN..1506.. |
| HSK100T-PDQNR-35200-15 | 35 | 63 | 200 | 171 | R | DN..1506.. |
| HSK100T-PDQNL-35200-15 | 35 | 63 | 200 | 171 | L | DN..1506.. |

HSK-T Turning Tool 长型 DDQNR | DDQNL 107.5°/55° 负前角刀片

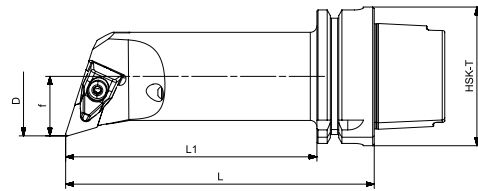
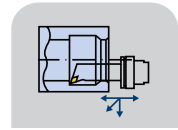

| Size | f | D min | L | L1 | Direction | Inserts N. |
|------------------------|----|-------|-----|-----|-----------|------------|
| HSK63T-DDQNR-27140-15 | 27 | 50 | 140 | 114 | R | DN..1506.. |
| HSK63T-DDQNL-27140-15 | 27 | 50 | 140 | 114 | L | DN..1506.. |
| HSK63T-DDQNR-27180-15 | 27 | 50 | 180 | 154 | R | DN..1506.. |
| HSK63T-DDQNL-27180-15 | 27 | 50 | 180 | 154 | L | DN..1506.. |
| HSK100T-DDQNR-27150-15 | 27 | 50 | 150 | 121 | R | DN..1506.. |
| HSK100T-DDQNL-27150-15 | 27 | 50 | 150 | 121 | L | DN..1506.. |
| HSK100T-DDQNR-27200-15 | 27 | 50 | 200 | 171 | R | DN..1506.. |
| HSK100T-DDQNL-27200-15 | 27 | 50 | 200 | 171 | L | DN..1506.. |
| HSK100T-DDQNR-35150-15 | 35 | 63 | 150 | 121 | R | DN..1506.. |
| HSK100T-DDQNL-35150-15 | 35 | 63 | 150 | 121 | L | DN..1506.. |
| HSK100T-DDQNR-35200-15 | 35 | 63 | 200 | 171 | R | DN..1506.. |
| HSK100T-DDQNL-35200-15 | 35 | 63 | 200 | 171 | L | DN..1506.. |

HSK

HSK-T Turning Tool SCLCR | SCLCL 95°/80° 正前角刀片

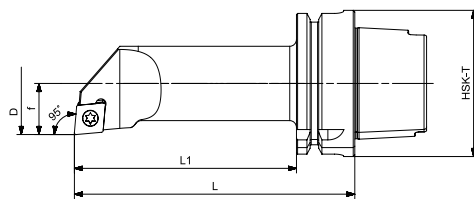
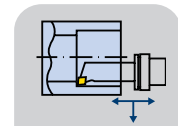

| Size | f | D min | L | L1 | Direction | Inserts N. |
|-----------------------|----|-------|-----|-----|-----------|------------|
| HSK63T-SCLCR-22125-12 | 22 | 40 | 125 | 99 | R | CC..1204.. |
| HSK63T-SCLCL-22125-12 | 22 | 40 | 125 | 99 | L | CC..1204.. |
| HSK63T-SCLCR-22160-12 | 22 | 40 | 160 | 134 | R | CC..1204.. |
| HSK63T-SCLCL-22160-12 | 22 | 40 | 160 | 134 | L | CC..1204.. |
| HSK63T-SCLCR-27140-12 | 27 | 50 | 140 | 114 | R | CC..1204.. |
| HSK63T-SCLCL-27140-12 | 27 | 50 | 140 | 114 | L | CC..1204.. |
| HSK63T-SCLCR-27180-12 | 27 | 50 | 180 | 154 | R | CC..1204.. |
| HSK63T-SCLCL-27180-12 | 27 | 50 | 180 | 154 | L | CC..1204.. |

HSK-T Turning Tool 长型 SVQCR | SVQCL 107.5°/55° 正前角刀片

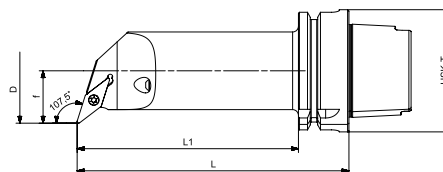
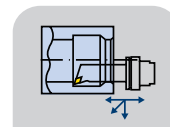

| Size | f | D min | L | L1 | Direction | Inserts N. |
|-----------------------|----|-------|-----|-----|-----------|------------|
| HSK63T-SVQCR11-85 | 13 | 25 | 85 | 59 | R | VC..1103.. |
| HSK63T-SVQCL11-85 | 13 | 25 | 85 | 59 | L | VC..1103.. |
| HSK63T-SVQCR11-100 | 17 | 32 | 100 | 74 | R | VC..1103.. |
| HSK63T-SVQCL11-100 | 17 | 32 | 100 | 74 | L | VC..1103.. |
| HSK63T-SVQCR-22125-16 | 22 | 40 | 125 | 99 | R | VC..1604 |
| HSK63T-SVQCL-22125-16 | 22 | 40 | 125 | 99 | L | VC..1604 |
| HSK63T-SVQCR-22160-16 | 22 | 40 | 160 | 134 | R | VC..1604 |
| HSK63T-SVQCL-22160-16 | 22 | 40 | 160 | 134 | L | VC..1604 |
| HSK63T-SVQCR-27140-16 | 27 | 50 | 140 | 114 | R | VC..1604 |
| HSK63T-SVQCL-27140-16 | 27 | 50 | 140 | 114 | L | VC..1604 |
| HSK63T-SVQCR-27180-16 | 27 | 50 | 180 | 154 | R | VC..1604 |
| HSK63T-SVQCL-27180-16 | 27 | 50 | 180 | 154 | L | VC..1604 |