

TOOL HOLDERS

HSK-T

HSK-T TOOLING SYSTEM

HSK-T 工具系统

HSK-T Boring Bar Holder004	复合刀具, 镗孔刀夹
HSK-T Turning Tools for Facing005	复合车刀座, 端面加工
HSK-T Turning Tools for External and Facing....006	复合车刀座, 外径端面加工
HSK-T Turning Tools for External and Cut-off....007	复合车刀座, 外径切断加工
HSK-T Turning Tools for External and Facing....008	复合车刀座, 外径端面加工
HSK-T Turning Tools for Internal.....009	复合车刀座, 内孔加工
HSK-T Turning Tool DCLNR DCLNL 95°/80°.....011	负前角刀片
HSK-T Turning Tool PCLNR PCLNL 95°/80°.....012	负前角刀片
HSK-T Turning Tool DCMNN 50°/80°/50°.....013	负前角刀片
HSK-T Turning Tool PCMNN 50°/80°/50°.....014	负前角刀片
HSK-T Turning Tool DDJNR DDJNL 55°/93°.....015	负前角刀片
HSK-T Turning Tool PDJNR PDJNL 55°/93°.....016	负前角刀片
HSK-T Turning Tool DDNNN 62.5°/55°/62.5°.....017	负前角刀片
HSK-T Turning Tool PDNNN 62.5°/55°/62.5°.....018	负前角刀片
HSK-T Turning Tool DDUNR DDUNL 93°/55°.....019	负前角刀片
HSK-T Turning Tool PDUNR PDUNL 93°/55°.....020	负前角刀片
HSK-T Turning Tool DSBNR DSBNL 90°/75°.....021	负前角刀片
HSK-T Turning Tool PSBNR PSBNL 90°/75°.....022	负前角刀片
HSK-T Turning Tool DSSNR DSSNL 45°/90°.....023	负前角刀片
HSK-T Turning Tool PSSNR PSSNL 45°/90°.....024	负前角刀片
HSK-T Turning Tool DVPNR DVPNL 117.5°/35°....025	负前角刀片
HSK-T Turning Tool DVUNR DVUNL 93°/35°.....026	负前角刀片
HSK-T Turning Tool DVWNN 72.5°/35°/72.5°.....027	负前角刀片
HSK-T Turning Tool DVJNR DVJNL 93°/35°.....028	负前角刀片
HSK-T Turning Tool DWLNR DWLNL 95°/80°.....029	负前角刀片
HSK-T Turning Tool PWLNR PWLNL 95°/80°.....030	负前角刀片
HSK-T Turning Tool 长型 DCLNR DCLNL 95°/80°.....031	负前角刀片
HSK-T Turning Tool 长型 PCLNR PCLNL 95°/80°.....032	负前角刀片

HSK-T Turning Tool 长型 DDQNR DDQNL 107.5°/55°.....033	负前角刀片
HSK-T Turning Tool 长型 PDQNR PDQNL 107.5°/55°.....034	负前角刀片
HSK-T Turning Tool SCLCR SCLCL 95°/80°.....035	正前角刀片
HSK-T Turning Tool SCMCN 50°/80°/50°.....036	正前角刀片
HSK-T Turning Tool SDHCR SDHCL 107.5°/55°.....037	正前角刀片
HSK-T Turning Tool SDNCN 62.5°/55°/62.5°.....038	正前角刀片
HSK-T Turning Tool SDJCR SDJCL 93°/55°.....039	正前角刀片
HSK-T Turning Tool SDUCR SDUCL 93°/55°.....040	正前角刀片
HSK-T Turning Tool SSBGR SSBGL 75°/90°.....041	正前角刀片
HSK-T Turning Tool SSSCR SSSCL 45°/90°.....042	正前角刀片
HSK-T Turning Tool SVPBR SVPBL SVPCR SVPLC 117.5°/35°.....043	正前角刀片
HSK-T Turning Tool SVUBR SVUBL SVUCR SVUCL 93°/35°.....044	正前角刀片
HSK-T Turning Tool SWBGR SWBGL SWVCR SWVCL 72.5°/35°/72.5°.....045	正前角刀片
HSK-T Turning Tool SVJBR SVJBL SVJCR SVJCL 93°/35°.....046	正前角刀片
HSK-T Turning Tool SCLCR SCLCL 95°/80°.....047	正前角刀片
HSK-T Turning Tool 长型 SDQCR SDQCL 107.5°/55°.....048	正前角刀片
HSK-T Turning Tool 长型 SVQCR SVQCL 107.5°/55°.....049	正前角刀片



HSK-T 车刀刀体

HSK-T External toolholders – Metric

刀柄尺寸 Taper Size	可转位刀片夹紧方式 Insert Clamping Way	可转位刀片形状 Insert Shape	刀杆偏角 Holder Angle	可转位刀片后角 Insert Clearance Angle	切削方向 Direction	刀片尺寸 Insert Size (mm)	L	f (mm)
HSK63T	C 从上面压紧 Clamp	C 80°	A 90°	B 5°	R 右 Right	16	70	45
HSK100T	D 从上面穿过孔压紧 Clamp/inserts with center hole	D 55°	B 75°	C 7°	L 左 Left			
	M 从上面用孔压紧 Pin/Clamp	S 90°	D 45°	N 0°	N 左右切 Both			
	P 压板夹紧 Pin/Wedge or Lever	V 35°	E 60°					
	S 通过孔拧紧 Screw	W 80°	G 90°					
			H 107.5°					
			J 93°					
			L 95°					
			M 50°					
			N 62.5°					
			P 117.5°					
			Q 107.5°					
			R 75°					
			S 45°					
			U 93°					
			V 72.5°					

HSK63T

D

C

L

N

HSK

刀柄尺寸
Taper Size

可转位刀片夹紧方式
Insert Clamping Way

可转位刀片形状
Insert Shape

刀杆偏角
Holder Angle

可转位刀片后角
Insert Clearance Angle

HSK63T
HSK100T

C		从上面压紧 Clamp
D		从上面穿过孔压紧 Clamp/inserts with center hole
M		从上面用孔压紧 Pin/Clamp
P		杠杆压紧 Pin/Wedge or Lever
S		通过孔拧紧 Screw

C		80°
D		55°
S		90°
V		35°
W		80°

A		90°
B		75°
D		45°
G		90°
H		107.5°
J		93°
L		95°
M		50°
N		62.5°
P		117.5°
Q		107.5°
R		75°
S		45°
U		93°
V		72.5°

B		5°
C		7°
N		0°

HSK

63T

刀柄款式
Taper

HSK

刀柄尺寸
Taper Size

HSK63T

HSK100T

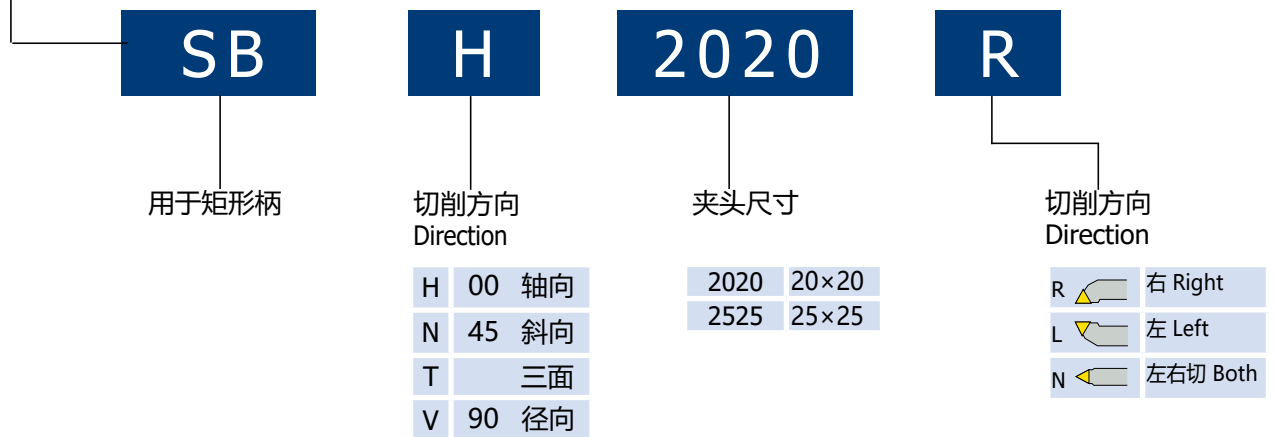
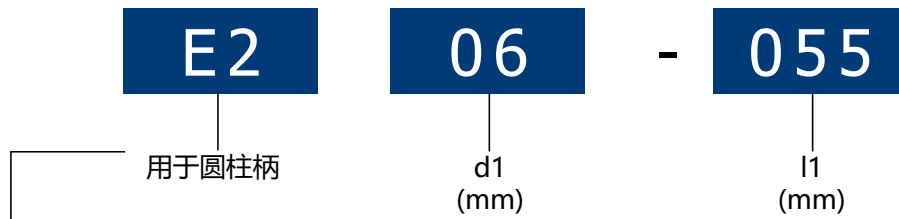
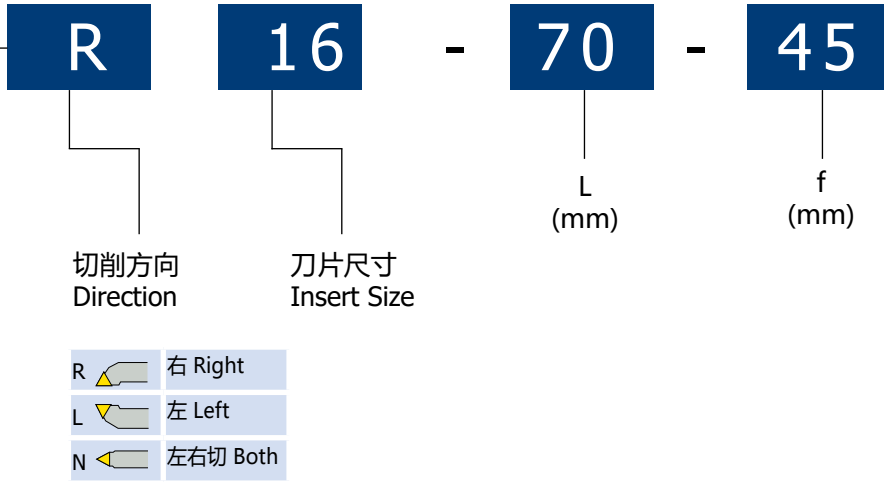





车刀刀体 HSK-T

车刀刀体 HSK-T 产品总览

HSK

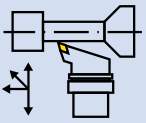
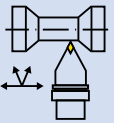
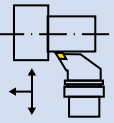
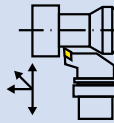
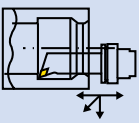
刀片形状 Insert Shape	DCLN PCLN 90° / 80°	DCMNN PCMNN 50° / 80° / 50°	PCLN 长型 95° / 80°		
C					
刀片形状 Insert Shape	DDJN PDJN 55° / 93°	DDNPN PDPNN 62.5° / 55° / 62.5°	DDUN PDUN 93° / 55°	DDQN PDQN 长型 107.5° / 55°	
D					
刀片形状 Insert Shape	DSBN PSBN 90° / 75°	DSSN PSSN 45° / 90°			
S					
刀片形状 Insert Shape	DVPCR DVPNL 117.5° / 35°	DVUNR DVUNL 93° / 35°	DVVNN 72.5° / 35° / 72.5°		
V					
刀片形状 Insert Shape	DWLN PVLN 90° / 80°				
W					
刀片形状 Insert Shape	SCLCR SCLCL 95° / 80°	SCMCN 50° / 80° / 50°	SCLC 长型 95° / 80°		
C					

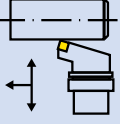
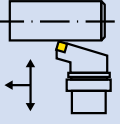
车刀刀体 HSK-T 车刀刀体 HSK-T 产品总览

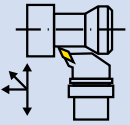
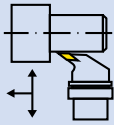
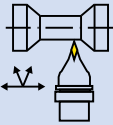
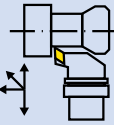
刀片形状 Insert Shape	SDHCR SDHCL 107.5° / 55°	SDNCN 62.5°/55°/62.5°	SDJCR SDJCL 93° / 55°	SDUCR SDUCL 93° / 55°	SDQC 长型 107.5° / 55°
D 					
刀片形状 Insert Shape	SSBCR SSBCL 75° / 90°	SSSCR SSSCL 45° / 90°			
S 					
刀片形状 Insert Shape	SVPB SVPC 117.5° / 35°	SVUB SVUC 93° / 35°	SVVB SVVC 72.5° / 35° / 72.5°	SVJB SVJC 93° / 35°	SVQC 107.5° / 55°
V 					

HSK-T Boring Bar Holder

复合刀具, 镗孔刀夹

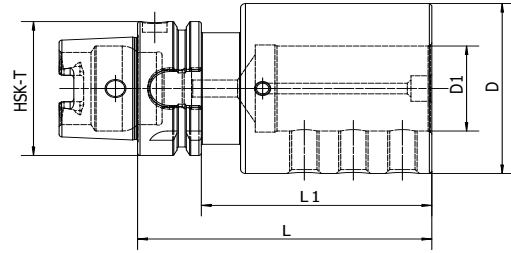

Size	D1	D	L	L1
HSK40T-E2-06-055	6	34	55	35
HSK40T-E2-08-055	8	34	55	35
HSK40T-E2-10-055	10	34	55	35
HSK40T-E2-12-055	12	36	55	35
HSK40T-E2-16-070	16	40	70	50
HSK40T-E2-20-085	20	44	85	65
HSK63T-E2-06-060	6	34	60	34
HSK63T-E2-08-060	8	34	60	34
HSK63T-E2-10-060	10	34	60	34
HSK63T-E2-12-060	12	36	60	34
HSK63T-E2-16-075	16	40	75	49
HSK63T-E2-20-075	20	44	75	49
HSK63T-E2-25-075	25	50	75	49
HSK63T-E2-32-090	32	56	90	64
HSK63T-E2-40-090	40	63	90	64
HSK100T-E2-06-070	6	34	70	41
HSK100T-E2-08-070	8	34	70	41
HSK100T-E2-10-070	10	34	70	41
HSK100T-E2-12-070	12	36	70	41
HSK100T-E2-16-085	16	40	85	56
HSK100T-E2-20-085	20	44	85	56
HSK100T-E2-25-085	25	50	85	56
HSK100T-E2-32-100	32	56	100	71
HSK100T-E2-40-100	40	63	100	71
HSK100T-E2-50-100	50	-	-	-

HSK-T Turning Tools for Facing
复合车刀座, 端面加工

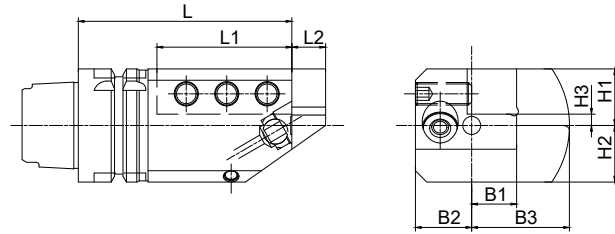

Size	L	L1	L2	B1	B2	B3	H1	H2	H3	G
HSK50T-SBV2020R-105	105	60	15	20	25	43.5	25	25	5	M10
HSK50T-SBV2020L-105	105	60	15	20	25	43.5	25	25	5	M10
HSK63T-SBV2020R-105	105	60	15	20	32	43.5	33	32	13	M10
HSK63T-SBV2020L-105	105	60	15	20	32	43.5	33	32	13	M10
HSK63T-SBV2525R-115	115	70	20	25	32	45	30	30	5	M12
HSK63T-SBV2525L-115	115	70	20	25	32	45	30	30	5	M12
HSK100T-SBV2525R-160	160	110	20	25	37	59	48	43	23	M12
HSK100T-SBV2525L-160	160	110	20	25	37	59	48	43	23	M12
HSK100T-SBV3232R-160	160	110	20	32	40	68.5	45	43	15	M14
HSK100T-SBV3232L-160	160	110	20	32	40	68.5	45	43	15	M14

HSK

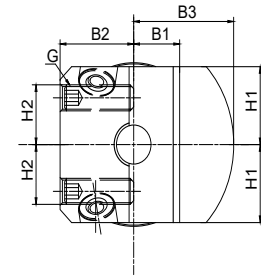
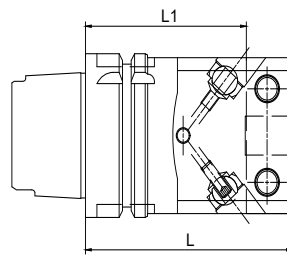
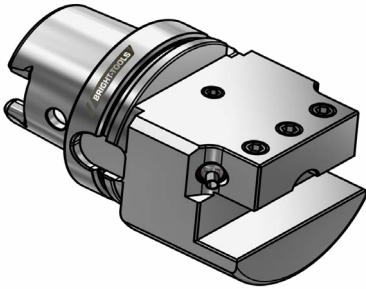
HSK-T Turning Tools for External and Facing
复合车刀座, 外径端面加工

Size	L	L1	B1	B2	B3	H1	H2	G
HSK50T-SBH2020N-100	100	80	20	25	43.5	27.5	-	M10
HSK50T-SBH2020N-130	130	110	20	25	43.5	27.5	-	M10
HSK63T-SBH2020N-100	100	80	20	32	43.5	30	-	M10
HSK63T-SBH2525N-100	100	75	25	32	53	40.5	29.5	M12
HSK63T-SBH2525N-130	130	105	25	32	53	40.5	29.5	M12
HSK100T-SBH2525N-115	115	90	25	32	59	48	37	M12
HSK100T-SBH2525N-160	160	135	25	32	59	48	37	M12
HSK100T-SBH3232N-115	115	85	32	40	68.5	57	43	M14

HSK-T Turning Tools for External and Cut-off

复合车刀座, 外径切断加工

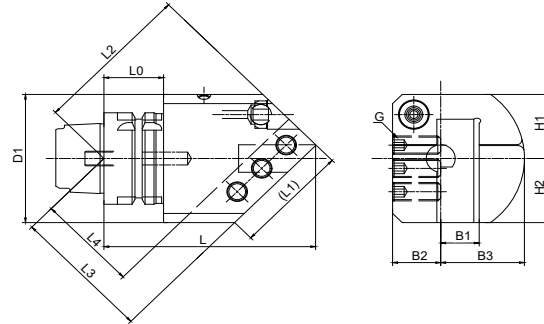

Size	L	L1	L2	L3	L4	D1	B1	B2	B3	H1	H2	G
HSK50T-SBN2020R-120	120	60	83.1	72.8	52.8	-	20	25	43.5	35	35	M10
HSK50T-SBN2020L-120	120	60	83.1	72.8	52.8	-	20	25	43.5	35	35	M10
HSK63T-SBN2020R-120	120	60	83.1	72.8	52.8	-	20	32	43.5	35	35	M10
HSK63T-SBN2020L-120	120	60	83.1	72.8	52.8	-	20	32	43.5	35	35	M10
HSK63T-SBN2525R-120	120	70	85.2	70.8	45.8	90	25	32	53	39	39	M12
HSK63T-SBN2525L-120	120	70	85.2	70.8	45.8	90	25	32	53	39	39	M12
HSK100T-SBN2525R-145	145	70	102.9	88.5	63.5	-	25	32	59	43	43	M12
HSK100T-SBN2525L-145	145	70	102.9	88.5	63.5	-	25	32	59	43	43	M12
HSK100T-SBN3232R-150	150	85	109.9	89	59	-	32	37	68.5	48	43	M14
HSK100T-SBN3232L-150	150	85	109.9	89	59	-	32	37	68.5	48	43	M14

HSK

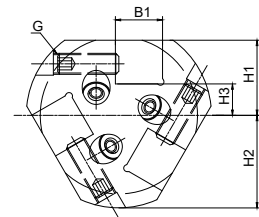
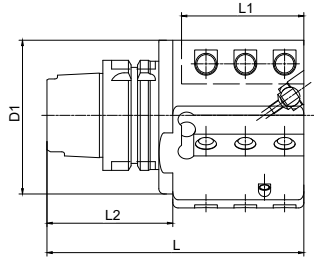
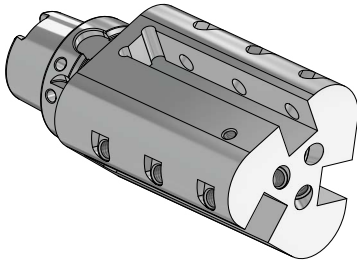
HSK-T Turning Tools for External and Facing
复合车刀座, 外径端面加工

Size	L	L1	L2	D1	B1	H1	H2	H3	G
HSK50T-SBT2020R-105	105	60	-	-	20	35	43.5	15	M10
HSK50T-SBT2020L-105	105	60	-	-	20	35	43.5	15	M10
			-	-	20	35	43.5	15	M10
HSK63T-SBT2020R-105	105	60	-	-	20	35	43.5	15	M10
HSK63T-SBT2020L-105	105	60							
HSK63T-SBT2525R-125	125	70	40	90	25	43	53	18	M12
HSK63T-SBT2525L-125	125	70	40	90	25	43	53	18	M12
HSK100T-SBT2525R-160	160	110	-	-	25	48	59	23	M12
HSK100T-SBT2525L-160	160	110	-	-	25	48	59	23	M12

HSK-T Turning Tools for Internal
复合车刀座, 内孔加工

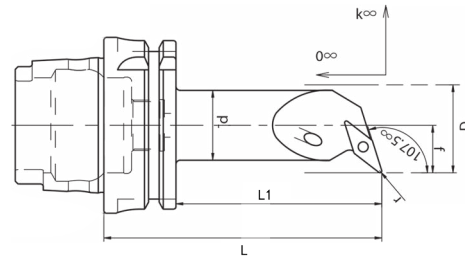

Size	d	L	L1	f	k°	D	r	Inserts N.
HSK63T-SVQBR11-85	20	85	59	13	-8	25	0.4	VB..1102..
HSK63T-SVQBL11-85	20	85	59	13	-8	25	0.4	VB..1102..
HSK63T-SVQBR11-100	25	100	74	17	-5	32	0.4	VB..1102..
HSK63T-SVQBL11-100	25	100	74	17	-5	32	0.4	VB..1102..
HSK63T-SVQBR16-120	32	120	94	22	-10	40	0.8	VB..1604..
HSK63T-SVQBL16-120	32	120	94	22	-10	40	0.8	VB..1604..
HSK63T-SVQBR16-140	40	140	114	27	-10	50	0.8	VB..1604..
HSK63T-SVQBL16-140	40	140	114	27	-10	50	0.8	VB..1604..

HSK

HSK-T Turning Tool DCLNR | DCLNL 95°/80°
负前角刀片

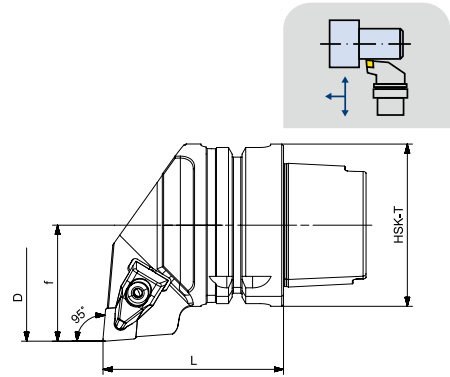

Size	f	D	L	Direction	Inserts N.
HSK63T-DCLNR-45070-12	45	80	70	R	CN..1204..
HSK63T-DCLNL-45070-12	45	80	70	L	CN..1204..
HSK63T-DCLNR-45070-16	45	80	70	R	CN..1606..
HSK63T-DCLNL-45070-16	45	80	70	L	CN..1606..
HSK100T-DCLNR-63100-12	63	120	100	R	CN..1204..
HSK100T-DCLNL-63100-12	63	120	100	L	CN..1204..
HSK100T-DCLNR-63100-16	63	120	100	R	CN..1606..
HSK100T-DCLNL-63100-16	63	120	100	L	CN..1606..

HSK-T Turning Tool PCLNR | PCLNL 95°/80°

负前角刀片

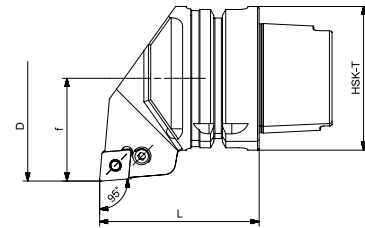
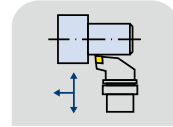

Size	f	D	L	Direction	Inserts N.
HSK63T-PCLNR-45070-12	45	80	70	R	CN..1204..
HSK63T-PCLNL-45070-12	45	80	70	L	CN..1204..
HSK63T-PCLNR-45070-16	45	80	70	R	CN..1606..
HSK63T-PCLNL-45070-16	45	80	70	L	CN..1606..
HSK100T-PCLNR-63100-12	63	120	100	R	CN..1204..
HSK100T-PCLNL-63100-12	63	120	100	L	CN..1204..
HSK100T-PCLNR-63100-16	63	120	100	R	CN..1606..
HSK100T-PCLNL-63100-16	63	120	100	L	CN..1606..
HSK100T-PCLNR-63100-19	63	120	100	R	CN..1906..
HSK100T-PCLNL-63100-19	63	120	100	L	CN..1906..

HSK-T Turning Tool DCMNN 50°/80°/50°
负前角刀片

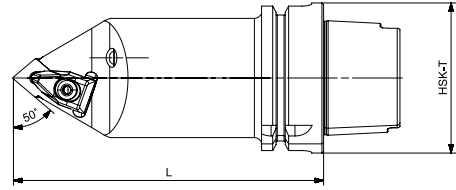
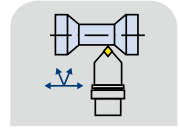

Size	L	Direction	Inserts N.
HSK63T-DCMNN-100-12	100	N	CN..1204..
HSK63T-DCMNN-130-12	130	N	CN..1204..
HSK63T-DCMNN-100-16	100	N	CN..1606..
HSK63T-DCMNN-130-16	130	N	CN..1606..
HSK100T-DCMNN-125-12	125	N	CN..1204..
HSK100T-DCMNN-125-16	125	N	CN..1606..

HSK

HSK-T Turning Tool PCMNN 50°/80°/50° 负前角刀片

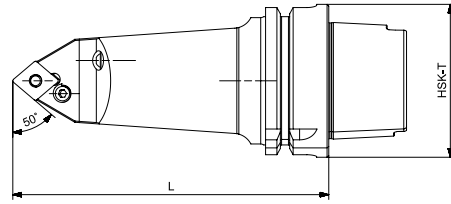
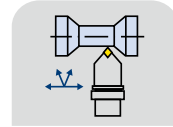

Size	L	Direction	Inserts N.
HSK63T-PCMNN-100-12	100	N	CN..1204..
HSK63T-PCMNN-130-12	130	N	CN..1204..
HSK63T-PCMNN-100-16	100	N	CN..1606..
HSK63T-PCMNN-130-16	130	N	CN..1606..
HSK100T-PCMNN-125-12	125	N	CN..1204..
HSK100T-PCMNN-125-16	125	N	CN..1606..

HSK-T Turning Tool DDJNR | DDJNL 55°/93°
负前角刀片

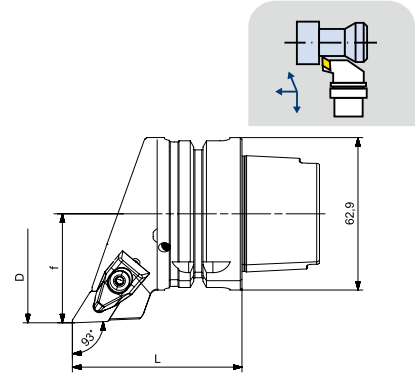

Size	f	L	Direction	Inserts N.
HSK63T-DDJNR-45075-15	45	70	R	DN..1506..
HSK63T-DDJNL-45075-15	45	70	L	DN..1506..
HSK100T-DDJNR-63100-15	63	100	R	DN..1506..
HSK100T-DDJNL-63100-15	63	100	L	DN..1506..

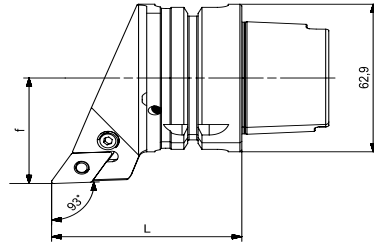
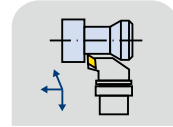
HSK-T Turning Tool PDJNR | PDJNL 55°/93°
负前角刀片

Size	f	L	Direction	Inserts N.
HSK63T-PDJNR-45070-15	45	70	R	DN..1506..
HSK63T-PDJNL-45070-15	45	70	L	DN..1506..
HSK100T-PDJNR-63100-15	63	100	R	DN..1506..
HSK100T-PDJNL-63100-15	63	100	L	DN..1506..

HSK-T Turning Tool DDNNN 62.5°/55°/62.5°
负前角刀片

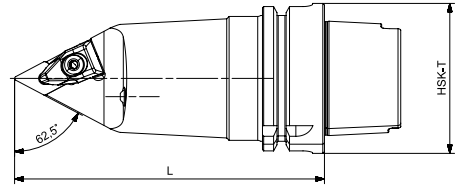
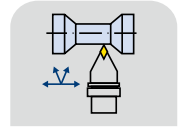

Size	L	Direction	Inserts N.
HSK63T-DDNNN-100-15	100	N	DN..1506..
HSK63T-DDNNN-130-15	130	N	DN..1506..
HSK100T-DDNNN-125-15	125	N	DN..1506..

HSK-T Turning Tool PDNNN 62.5°/55°/62.5°

负前角刀片

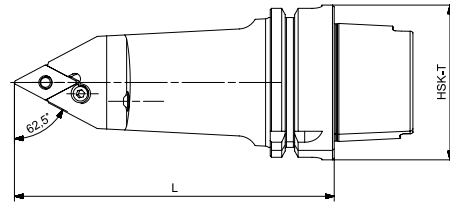
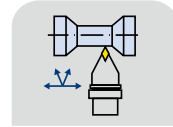

Size	L	Direction	Inserts N.
HSK63T-PDNNN-100-15	100	N	DN..1506..
HSK63T-PDNNN-130-15	130	N	DN..1506..
HSK100T-PDNNN-125-15	125	N	DN..1506.. DN..1506..

HSK-T Turning Tool DDUNR | DDUNL 93°/55°
负前角刀片

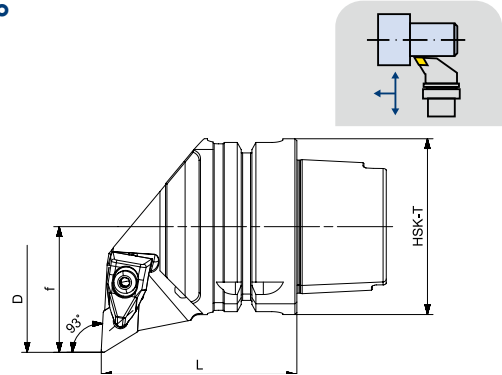

Size	f	D	L	Direction	Inserts N.
HSK63T-DDUNR-45070-15	45	80	70	R	DN..1506..
HSK63T-DDUNL-45070-15	45	80	70	L	DN..1506..
HSK100T-DDUNR-63100-15	63	120	100	R	DN..1506..
HSK100T-DDUNL-63100-15	63	120	100	L	DN..1506..

HSK-T Turning Tool PDUNR | PDUNL 93°/55° 负前角刀片

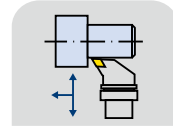
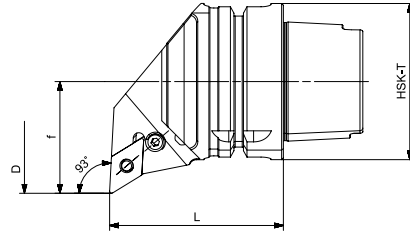

Size	f	D	L	Direction	Inserts N.
HSK63T-PDUNR-45070-15	45	80	70	R	DN..1506..
HSK63T-PDUNL-45070-15	45	80	70	L	DN..1506..
HSK100T-PDUNR-63100-15	63	120	100	R	DN..1506..
HSK100T-PDUNL-63100-15	63	120	100	L	DN..1506..

HSK-T Turning Tool DSBNR | DSBNL 90°/75°
负前角刀片

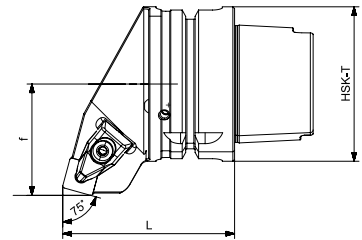
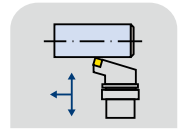

Size	f	L	Direction	Inserts N.
HSK63T-DSB NR-45070-12	45	70	R	SN..1204..
HSK63T-DSBNL-45070-12	45	70	L	SN..1204..
HSK100T-DSB NR-63100-12	63	100	R	SN..1204..
HSK100T-DSBNL-63100-12	63	100	L	SN..1204..

HSK-T Turning Tool PSBNR | PSBNL 90°/75° 负前角刀片

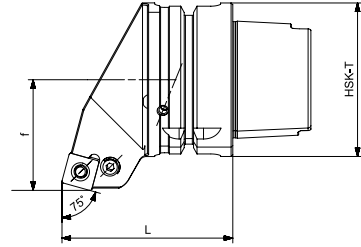
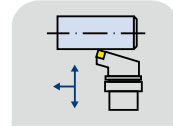

Size	f	L	Direction	Inserts N.
HSK63T-PSBNR-45070-12	45	70	R	SN..1204..
HSK63T-PSBNL-45070-12	45	70	L	SN..1204..
HSK100T-PSBNR-63100-12	63	100	R	SN..12 04..
HSK100T-PSBNL-63100-12	63	100	L	SN..1204..

HSK-T Turning Tool DSSNR | DSSNL 45°/90°
负前角刀片

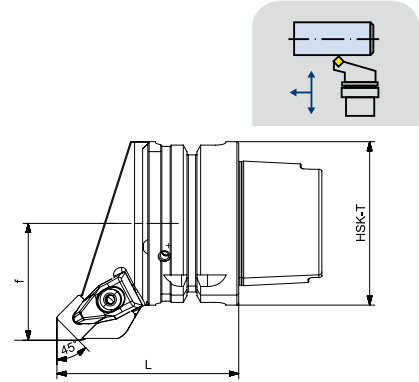

Size	f	D	L	Direction	Inserts N.
HSK63T-DSSNR-45070-12	45	-	70	R	SN..1204..
HSK63T-DSSNL-45070-12	45	-	70	L	SN..1204..
HSK100T-DSSNR-63100-12	63	-	100	R	SN..1204..
HSK100T-DSSNL-63100-12	63	-	100	L	SN..1204..

HSK-T Turning Tool PSSNR | PSSNL 45°/90°

负前角刀片

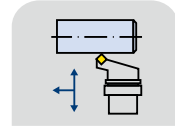
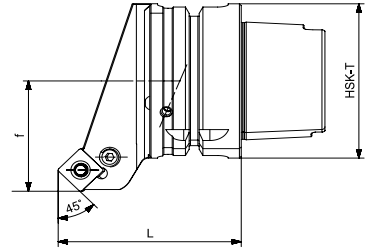

Size	f	L	Direction	Inserts N.
HSK63T-PSSNR-45070-12	45	70	R	SN..1204..
HSK63T-PSSNL-45070-12	45	70	L	SN..1204..
HSK100T-PSSNR-63100-12	63	100	R	SN..1204..
HSK100T-PSSNL-63100-12	63	100	L	SN..1204..

HSK-T Turning Tool DVPNR | DVPNL 117.5°/35°

负前角刀片

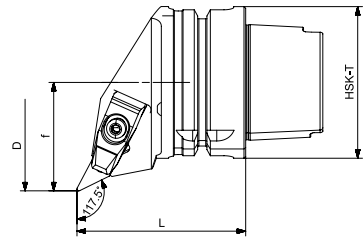
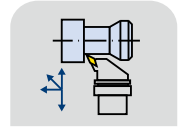

Size	f	D	L	Direction	Inserts N.
HSK63T-DVPCR-45070-16	45	80	70	R	VN..1604..
HSK63T-DVPNL-45070-16	45	80	70	L	VN..1604..
HSK100T-DVPCR-63100-16	63	120	100	R	VN..1604..
HSK100T-DVPNL-63100-16	63	120	100	L	VN..1604..

HSK

HSK-T Turning Tool DVUNR | DVUNL 93°/35°

负前角刀片

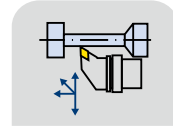
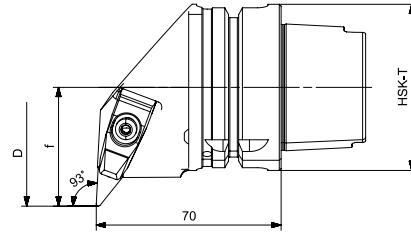

Size	f	D	L	Direction	Inserts N.
HSK63T-DVUNR-45070-16	45	80	70	R	VN..1604..
HSK63T-DVUNL-45070-16	45	80	70	L	VN..1604..
HSK100T-DVUNR-63100-16	63	120	100	R	VN..1604..
HSK100T-DVUNL-63100-16	63	120	100	L	VN..1604..

HSK-T Turning Tool DVVNN 72.5°/35°/72.5°

负前角刀片

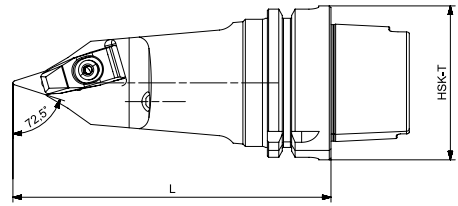
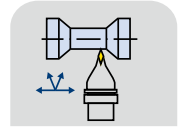

Size	L	Direction	Inserts N.
HSK63T-DVVNN-100-16	100	N	VN..1604..
HSK63T-DVVNN-130-16	130	N	VN..1604..
HSK100T-DVVNN-125-16	125	N	VN..1604..

HSK-T Turning Tool DWLNR | DWLNL 95°/80°

负前角刀片

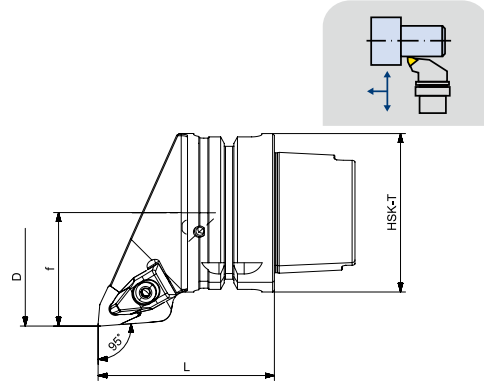

Size	f	D	L	Direction	Inserts N.
HSK63T-DWLNR-45070-8	45	80	70	R	WN..0804..
HSK63T-DWLNL-45070-8	45	80	70	L	WN..0804..
HSK100T-DWLNR-63100-8	63	120	100	R	WN..0804..
HSK100T-DWLNL-63100-8	63	120	100	L	WN..0804..

HSK-T Turning Tool PWLNR | PWLNL 95°/80°
负前角刀片

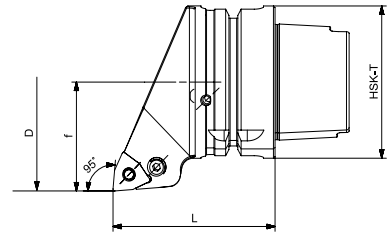
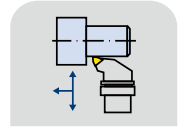

Size	f	D	L	Direction	Inserts N.
HSK63T-PWLNR-45070-8	45	80	70	R	WN..0804..
HSK63T-PWLNL-45070-8	45	80	70	L	WN..0804..
HSK100T-PWLNR-63100-8	63	120	100	R	WN..0804..
HSK100T-PWLNL-63100-8	63	120	100	L	WN..0804..

HSK-T Turning Tool 长型 PCLNR | PCLNL 95°/80° 负前角刀片

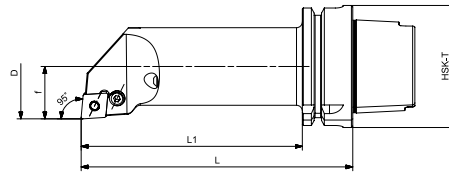
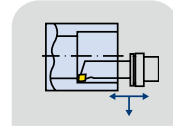

Size	f	D	L	L1	Direction	Inserts N.
HSK63T-PCLNR-27140-12	27	50	140	114	R	CN..1204..
HSK63T-PCLNL-27140-12	27	50	140	114	L	CN..1204..
HSK63T-PCLNR-27180-12	27	50	180	154	R	CN..1204..
HSK63T-PCLNL-27180-12	27	50	180	154	L	CN..1204..
HSK100T-PCLNR-27150-12	27	50	150	121	R	CN..1204..
HSK100T-PCLNL-27150-12	27	50	150	121	L	CN..1204..
HSK100T-PCLNR-27200-12	27	50	200	171	R	CN..1204..
HSK100T-PCLNL-27200-12	27	50	200	171	L	CN..1204..
HSK100T-PCLNR-35150-12	35	63	150	121	R	CN..1204..
HSK100T-PCLNL-35150-12	35	63	150	121	L	CN..1204..
HSK100T-PCLNR-35200-12	35	63	200	171	R	CN..1204..
HSK100T-PCLNL-35200-12	35	63	200	171	L	CN..1204..

**HSK-T Turning Tool 长型 DDQNR | DDQNL 107.5°/55°
负前角刀片**

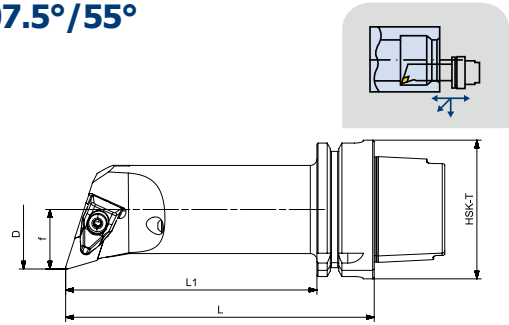

Size	f	D	L	L1	Direction	Inserts N.
HSK63T-DDQNR-27140-15	27	50	140	114	R	DN..1506..
HSK63T-DDQNL-27140-15	27	50	140	114	L	DN..1506..
HSK63T-DDQNR-27180-15	27	50	180	154	R	DN..1506..
HSK63T-DDQNL-27180-15	27	50	180	154	L	DN..1506..
HSK100T-DDQNR-27150-15	27	50	150	121	R	DN..1506..
HSK100T-DDQNL-27150-15	27	50	150	121	L	DN..1506..
HSK100T-DDQNR-27200-15	27	50	200	171	R	DN..1506..
HSK100T-DDQNL-27200-15	27	50	200	171	L	DN..1506..
HSK100T-DDQNR-35150-15	35	63	150	121	R	DN..1506..
HSK100T-DDQNL-35150-15	35	63	150	121	L	DN..1506..
HSK100T-DDQNR-35200-15	35	63	200	171	R	DN..1506..
HSK100T-DDQNL-35200-15	35	63	200	171	L	DN..1506..

HSK-T Turning Tool 长型 PDQNR | PDQNL 107.5°/55° 负前角刀片

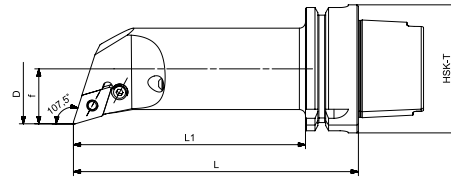
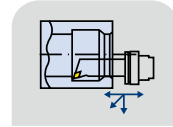

Size	f	D	L	L1	Direction	Inserts N.
HSK63T-PDQNR-27140-15	27	50	140	114	R	DN..1506..
HSK63T-PDQNL-27140-15	27	50	140	114	L	DN..1506..
HSK63T-PDQNR-27180-15	27	50	180	154	R	DN..1506..
HSK63T-PDQNL-27180-15	27	50	180	154	L	DN..1506..
HSK100T-PDQNR-27150-15	27	50	150	121	R	DN..1506..
HSK100T-PDQNL-27150-15	27	50	150	121	L	DN..1506..
HSK100T-PDQNR-27200-15	27	50	200	171	R	DN..1506..
HSK100T-PDQNL-27200-15	27	50	200	171	L	DN..1506..
HSK100T-PDQNR-35150-15	35	63	150	121	R	DN..1506..
HSK100T-PDQNL-35150-15	35	63	150	121	L	DN..1506..
HSK100T-PDQNR-35200-15	35	63	200	171	R	DN..1506..
HSK100T-PDQNL-35200-15	35	63	200	171	L	DN..1506..

HSK-T Turning Tool SCLCR | SCLCL 95°/80°
正前角刀片

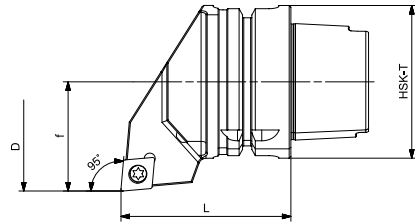
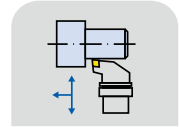

Size	f	D	L	Direction	Inserts N.
HSK63T-SCLCR-45070-12	45	80	70	R	CC..1204..
HSK63T-SCLCL-45070-12	45	80	70	L	CC..1204..
HSK100T-SCLCR-63100-12	63	120	100	R	CC..1204..
HSK100T-SCLCL-63100-12	63	120	100	L	CC..1204..

HSK-T Turning Tool SCMCN 50°/80°/50° 正前角刀片

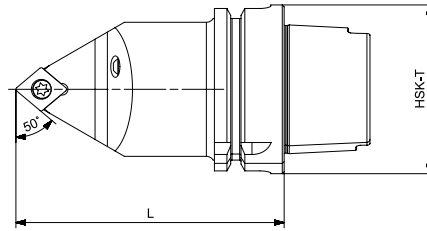
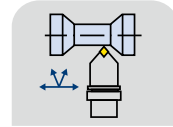

Size	L	Direction	Inserts N.
HSK63T-SCMCN-100-12	100	N	CC..1204..
HSK63T-SCMCN-130-12	130	N	CC..1204..
HSK100T-SCMCN-125-12	125	N	CC..1204..

HSK-T Turning Tool SDHCR | SDHCL 107.5°/55°

正前角刀片

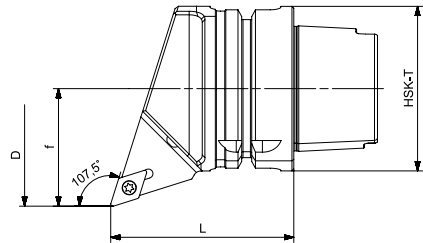
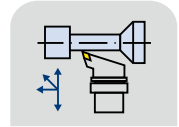

Size	f	D	L	Direction	Inserts N.
HSK63T-SDHCR-45070-11	45	80	70	R	DC..11T3..
HSK63T-SDHCL-45070-11	45	80	70	L	DC..11T3..
HSK100T-SDHCR-63100-11	63	120	100	R	DC..11T3..
HSK100T-SDHCL-63100-11	63	120	100	L	DC..11T3..

HSK

HSK-T Turning Tool SDNCN 62.5°/55°/62.5° 正前角刀片

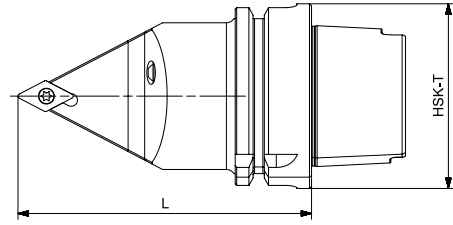
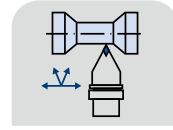

Size	L	Direction	Inserts N.
HSK63T-SDNCN-100-11	100	N	DC..11T3..
HSK63T-SDNCN-130-11	130	N	DC..11T3..
HSK100T-SDNCN-125-11	125	N	DC..11T3..

HSK-T Turning Tool SDJCR | SDJCL 93°/55°
正前角刀片

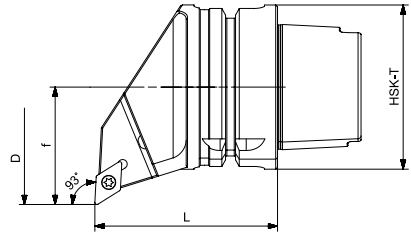
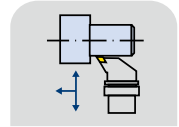

Size	f	D	L	Direction	Inserts N.
HSK63T-SDJCR-45070-11	45	80	70	R	DC..11T3..
HSK63T-SDJCL-45070-11	45	80	70	L	DC..11T3..
HSK100T-SDJCR-63100-11	63	120	100	R	DC..11T3..
HSK100T-SDJCL-63100-11	63	120	100	L	DC..11T3..

HSK

HSK-T Turning Tool SDUCR | SDUCL 93°/55°

正前角刀片

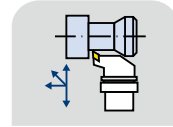
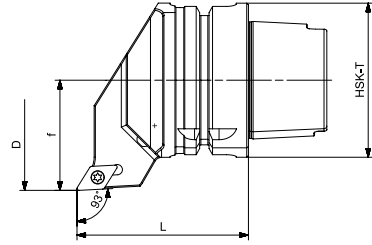

Size	f	D	L	Direction	Inserts N.
HSK63T-SDUCR-45070-11	45	80	70	R	DC..11T3..
HSK63T-SDUCL-45070-11	45	80	70	L	DC..11T3..
HSK100T-SDUCR-63100-11	63	120	100	R	DC..11T3..
HSK100T-SDUCL-63100-11	63	120	100	L	DC..11T3..

HSK-T Turning Tool SSBCR | SSBCL 75°/90°
正前角刀片

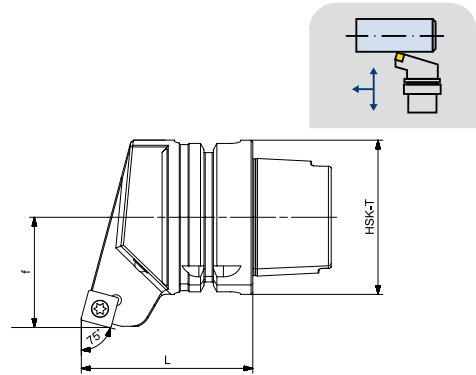

Size	f	L	Direction	Inserts N.
HSK63T-SSBCR-45070-12	45	70	R	SC..1204..
HSK63T-SSBCL-45070-12	45	70	L	SC..1204..
HSK100T-SSBCR-63100-12	63	100	R	SC..1204..
HSK100T-SSBCL-63100-12	63	100	L	SC..1204..

HSK-T Turning Tool SSSCR | SSSCL 45°/90°

正前角刀片

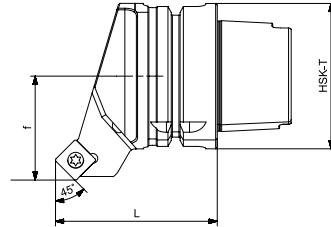
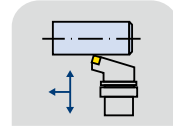

Size	f	L	Direction	Inserts N.
HSK63T-SSSCR-45070-12	45	70	R	SC..1204..
HSK63T-SSSCL-45070-12	45	70	L	SC..1204..
HSK100T-SSSCR-63100-12	63	100	R	SC..1204..
HSK100T-SSSCL-63100-12	63	100	L	SC..1204..

HSK-T Turning Tool SVPBR | SVPBL | SVPCR | SVPCL 117.5°/35°
正前角刀片

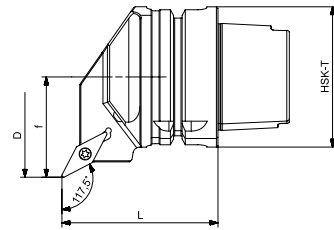
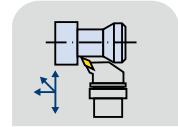

Size	f	D	L	Direction	Inserts N.
HSK63T-SVPBR-45070-16	45	80	70	R	VB..1604..
HSK63T-SVPBL-45070-16	45	80	70	L	VB..1604..
HSK63T-SVPCR-45070-16	45	80	70	R	VC..1604..
HSK63T-SVPCL-45070-16	45	80	70	L	VC..1604..
HSK100T-SVPBR-63100-16	63	120	100	R	VB..1604..
HSK100T-SVPBL-63100-16	63	120	100	L	VB..1604..
HSK100T-SVPCR-63100-16	63	120	100	R	VC..1604..
HSK100T-SVPCL-63100-16	63	120	100	L	VC..1604..

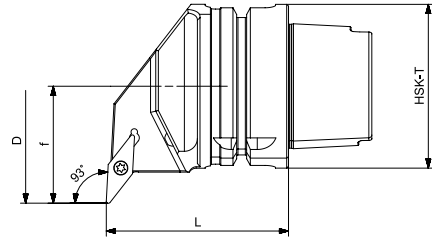
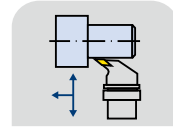
HSK-T Turning Tool SVUBR | SVUBL | SVUCR | SVUCL 93°/35°
正前角刀片

Size	f	D	L	Direction	Inserts N.
HSK63T-SVUBR-45070-16	45	80	70	R	VB..1604..
HSK63T-SVUBL-45070-16	45	80	70	L	VB..1604..
HSK63T-SVUCR-45070-16	45	80	70	R	VC..1604..
HSK63T-SVUCL-45070-16	45	80	70	L	VC..1604..
HSK100T-SVUBR-63100-16	63	120	100	R	VB..1604..
HSK100T-SVUBL-63100-16	63	120	100	L	VB..1604..
HSK100T-SVUCR-63100-16	63	120	100	R	VC..1604..
HSK100T-SVUCL-63100-16	63	120	100	L	VC..1604..

HSK-T Turning Tool SVVBN | SVVCN 72.5°/35°/72.5°
正前角刀片

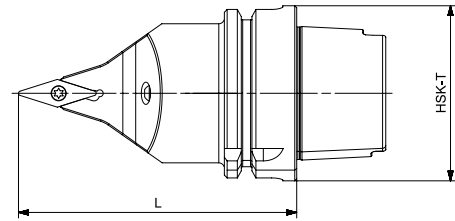
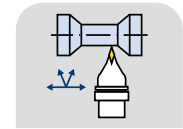

Size	L	Direction	Inserts N.
HSK63T-SVVBN-100-16	100	N	VB..1604..
HSK63T-SVVBN-130-16	130	N	VB..1604..
HSK63T-SVVCN-100-16	100	N	VC..1604..
HSK63T-SVVCN-130-16	130	N	VC..1604..
HSK100T-SVVBN-125-16	125	N	VB..1604..
HSK100T-SVVCN-125-16	125	N	VC..1604..

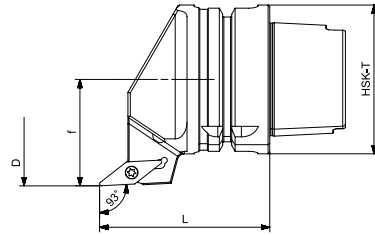
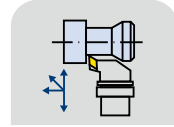
HSK-T Turning Tool SVJBR | SVJBL | SVJCR | SVJCL 93°/35°
正前角刀片

Size	f	D	L	Direction	Inserts N.
HSK63T-SVJBR-45072-16	45	80	71.5	R	VB..1604..
HSK63T-SVJBL-45072-16	45	80	71.5	L	VB..1604..
HSK63T-SVJCR-45072-16	45	80	71.5	R	VC..1604..
HSK63T-SVJCL-45072-16	45	80	71.5	L	VC..1604..
HSK100T-SVJBR-63100-16	63	120	100	R	VB..1604..
HSK100T-SVJBL-63100-16	63	120	100	L	VB..1604..
HSK100T-SVJCR-63100-16	63	120	100	R	VC..1604..
HSK100T-SVJCL-63100-16	63	120	100	L	VC..1604..

HSK-T Turning Tool SCLCR | SCLCL 95°/80°

正前角刀片

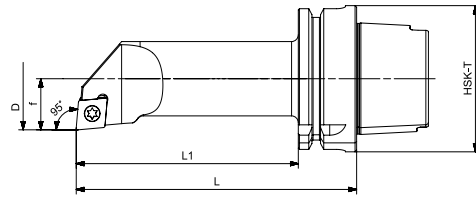
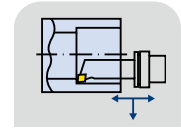

Size	f	D	L	L1	Direction	Inserts N.
HSK63T-SCLCR-22125-12	22	40	125	99	R	CC..1204..
HSK63T-SCLCL-22125-12	22	40	125	99	L	CC..1204..
HSK63T-SCLCR-22160-12	22	40	160	134	R	CC..1204..
HSK63T-SCLCL-22160-12	22	40	160	134	L	CC..1204..
HSK63T-SCLCR-27140-12	27	50	140	114	R	CC..1204..
HSK63T-SCLCL-27140-12	27	50	140	114	L	CC..1204..
HSK63T-SCLCR-27180-12	27	50	180	154	R	CC..1204..
HSK63T-SCLCL-27180-12	27	50	180	154	L	CC..1204..

HSK-T Turning Tool 长型 SDQCR | SDQCL 107.5°/55° 正前角刀片

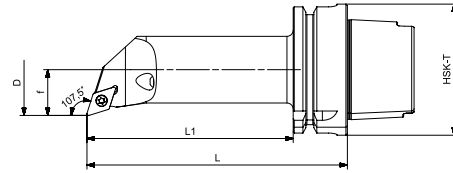
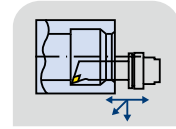

Size	f	D	L	Direction	Inserts N.
HSK63T-SDQCR-45070-11	45	80	70	R	DC..11T3..
HSK63T-SDQCL-45070-11	45	80	70	L	DC..11T3..
HSK100T-SDQCR-63100-11	63	120	100	R	DC..11T3..
HSK100T-SDQCL-63100-11	63	120	100	L	DC..11T3..

HSK-T Turning Tool 长型 SVQCR | SVQCL 107.5°/55°
正前角刀片

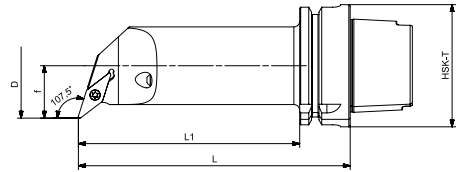

Size	f	D	L	L1	Direction	Inserts N.
HSK63T-SVQCR-22125-16	22	40	125	99	R	VB..T16T3
HSK63T-SVQCL-22125-16	22	40	125	99	L	VB..T16T3
HSK63T-SVQCR-22160-16	22	40	160	134	R	VB..T16T3
HSK63T-SVQCL-22160-16	22	40	160	134	L	VB..T16T3
HSK63T-SVQCR-27140-16	27	50	140	114	R	VB..T16T3
HSK63T-SVQCL-27140-16	27	50	140	114	L	VB..T16T3
HSK63T-SVQCR-27180-16	27	50	180	154	R	VB..T16T3
HSK63T-SVQCL-27180-16	27	50	180	154	L	VB..T16T3